

Wirefree Passive Infra-Red Movement Detector

Installation and Operating Instructions

These instructions should be read in conjunction with your System Installation and Operating Manual and be retained for future reference.

DECLARATION

Friedland hereby declares that this wirefree PIR Detector is in compliance with the essential requirements and other relevant provisions of the R&TTE directive (1999/5/EC).

INTRODUCTION

This Passive Infra-Red Movement Detector is suitable for use with Friedland Wirefree Intruder Alarm systems operating at 868MHz only.

PIR Detectors detect movement in a protected area by detecting changes in infra-red radiation levels caused for example when a person moves within or across the PIR's detection pattern. If movement is detected an alarm will be triggered, (if the system is armed). PIR Detectors will also detect animals, so ensure that pets are not permitted access to areas fitted with PIR Movement Detectors when the system is armed.

The detector incorporates a tamper protection feature to protect against attempts to interfere with the device. If the battery cover is removed, an alarm will immediately occur at any time (unless system is in Service, Test or Programming modes).

The detector also incorporates a sensitivity adjustment feature to compensate for situations where the detector may be triggered by environmental changes, (e.g. insects, air temperature, etc).

To conserve power and maximise battery life the PIR detector will only detect movement if there has been no movement detected within the previous 2 minutes.

The detector is powered by a PP3 Alkaline battery which under normal conditions will have an expected life in excess of 1 year. When the battery level drops, with the PIR in normal operation mode and the battery cover fitted, the LED behind the detection window will flash. When this occurs the battery should be replaced as soon as possible. (Note: in normal operation with the LED behind the lens will not flash on detection of movement).

POSITIONING THE PIR MOVEMENT DETECTOR

The PIR Movement Detector is suitable for mounting in dry interior locations only.

The recommended position for a PIR Movement Detector is in the corner of a room mounted at a height between 2 and 2.5m. At this height, the detector will have a range of up to 12m with a field of view of 110°.

When considering and deciding upon the mounting position for the detector the following points should be considered to ensure trouble free operation:

- Do not position the detector facing a window or where it is exposed to or facing direct sunlight. PIR Movement Detectors are not suitable for use in conservatories.

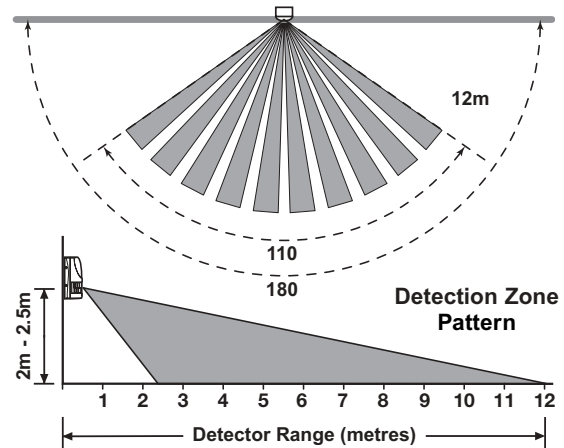

- Do not position the detector where it is exposed to draughts.
- Do not position the detector directly above a heat source, (e.g. fire, radiator, boiler, etc.).**
- Where possible, mount the detector in the corner of the room so that the logical path of an intruder would cut across the fan detection pattern. PIR detectors respond more effectively to movement across the device than to movement directly towards it.
- Do not position the detector in a position where it is subject to excessive vibration.
- Ensure that the position selected for the PIR detector is within effective range of the system, (refer to System Installation and Operating Manual).
- DO NOT fix the detector to metalwork or locate the unit within 1m of metalwork (i.e. radiators, water pipes, etc) as this could affect the radio range of the device.**

Note: When the system is Armed, pets should not be allowed into an area protected by a PIR Detector as their movement would trigger the PIR and trigger an alarm.

INSTALLING AND CONFIGURING THE PIR MOVEMENT DETECTOR

Ensure that the system is in Test/Service Mode.

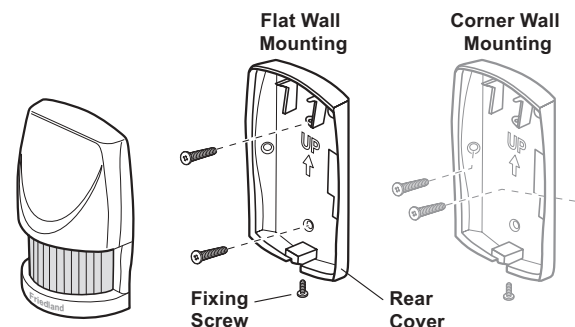

- Undo and remove the fixing screw from the bottom edge of the PIR Detector, (keep the screw safe for later). Carefully pull the bottom edge of the detector away from the rear cover and then slide down to release the top clips.

- Carefully drill out the required mounting holes in the rear cover using a 3mm drill according to whether the unit is being mounted in a corner or against a flat wall.
- Using the rear cover as a template, mark the positions of the fixing holes on the wall.
- Fix the rear cover to the wall using the two 18mm No.4 screws and 22mm wall plugs, (a 5mm hole will be required for the wall plugs). Do not over-tighten the screws as this may distort or damage the cover.

Note: The wall plugs supplied with the product are not suitable for plasterboard walls, if mounting the Detector onto plasterboard use appropriate wall plugs.

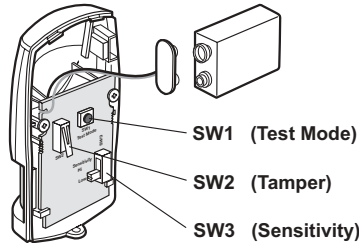

- To select the required sensitivity, set switch SW3 as follows:

UP HIGH sensitivity
DOWN LOW sensitivity

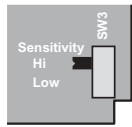

SW3 up
High Sensitivity

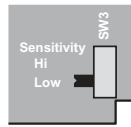

SW3 down
Low Sensitivity

Note: The recommended setting is HIGH. However, in cases of extreme environmental problems or if unexplained false alarms are experienced, it may be necessary to set the sensitivity to LOW. Setting the device to LOW sensitivity will require a greater amount of movement in order to trigger the device.

- Connect the PP3 Alkaline battery to the battery clip. The LED behind the lens will rapidly flash for approximately 2-3 minutes until the PIR has stabilised. The LED will then stop flashing and turn OFF.

Testing the PIR Detector independently for Walk Testing.

- Ensure that the LED indicator has stopped flashing rapidly.
- Button SW1 (Test Mode) is used to put the PIR Detector into Walk Test mode, which overrides the 2 minute sleep period and allows the operation of the detector to be checked during installation. Press and hold the button for 2s to activate test mode for a fixed 5 minute after which it will automatically revert to normal operation.

On initial installation the detector should be configured into Walk Test ready for testing, (i.e. Pressing down SW1 for 2s).

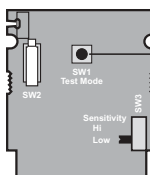

SW1 (Test Mode)
Press for 2 seconds to activate Walk Test mode

- Refit the PIR Detector to the rear cover by offering the detector up to the rear cover and locate the clips in the top edge into the rear cover. Push the lower edge of the detector into place and refit the fixing screw in the bottom edge of the PIR to secure in position. Do not over-tighten the screws as this may damage the casing.

- Walk into and move slowly around the protected area within the 5 minutes of pressing SW1. Each time the detector senses movement the LED indicator behind the lens will flash.

Linking the PIR Detector to the Alarm System.

- In order to communicate with the system, the ID code of the Detector needs to be learnt by the Control Panel when placed into Learn Mode (or for single zone systems, first place the Siren into Service Mode prior to Learn Mode).

Refer to the Installation and Operating manual for your system for adding additional detectors to your system.

- Ensure that the system is in switched back to Standby/Operating Mode.

It is recommended that the operation of the detector is also tested with the alarm in normal operating mode to ensure that the detector will successfully trigger a Full Alarm condition and that the Detector is operating on the correct zone (if installed on a multi zone alarm system). Refer to your System Installation and Operating Manual.

IMPORTANT: In normal operation, the LED indicator behind the detector lens will not flash on movement detection, (unless the battery is low).

When the detector is fully installed, i.e. battery cover fitted and in operating mode; in order to conserve power and maximise battery life the PIR Detector will only detect movement if there has been no movement detected within the previous 2 minutes.

DISPOSAL

At the end of their useful life the packaging, batteries and product should be disposed of via a suitable Recycling Centre. Do not dispose of with your normal household waste. DO NOT BURN.



GUARANTEE

Novar ED&S (A Honeywell Company) undertakes to replace or repair at its discretion goods (excluding non rechargeable batteries) should they become defective within 2 years solely as a result of faulty materials and workmanship. Understandably if the product has not been installed, operated or maintained or maintained in accordance with the instructions, has not been used appropriately or if any attempt has been made to rectify, dismantle or alter the product in any way the guarantee will be invalidated.

The guarantee states Novar ED&S entire liability. It does not extend to cover consequential loss or damage or installation costs arising from the defective product. This guarantee does not in any way affect the statutory or other rights of the consumer.

If an item develops a fault, the product must be returned to the point of sale with:

- Proof of purchase.
- A full description of the fault.
- All relevant batteries (disconnected).

Friedland is a trade mark of Novar ED&S.

HELPLINE

If you have any problems with your alarm, please call the Helpline on:

0870 850 3015

(Lines open 9.00am to 5.00pm, Monday to Friday.

Calls charged at service providers national rate).



Friedland, Novar Electrical Devices and Systems Limited. (A Honeywell Company)

The Arnold Centre, Paycocke Road, Basildon, Essex SS14 3EA. UK

www.friedland.co.uk.

51065PL Ed.1