

# Dummy Siren

## Installation and Operating Instructions

### KIT CONTENTS

The Dummy Siren should contain the following:

- 1 x Dummy Siren Unit
- 4 x 1.5V Alkaline C Batteries
- 1 x Clear Plastic Mounting Template
- 1 x 6mm Masonry Drill Bit
- Fixing Screws and Wall Plugs
- Instruction Leaflet

#### Tools and Equipment Required:

Small Spirit Level; Drill; 6mm Masonry Drill Bit; Bradawl.

### INSTALLATION

1. Remove the two screws on the battery compartment cover on the rear of the siren and remove the cover.
2. Insert the 4 batteries ensuring correct polarity
3. Refit the battery cover.

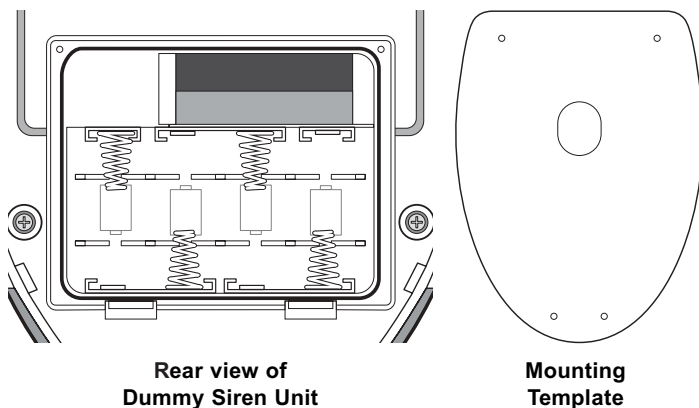

On the front face of the siren behind the red lens, you will now notice two red deterrent LEDs flashing alternately every 5 seconds.

4. Use the clear plastic mounting template to mark the positions of the four mounting holes shown. A spirit level placed on the top edge will help ensure you get the unit level.
5. Undo the fixing screw securing the mounting plate from the bottom edge of the siren and remove the plate.
6. Drill four 6mm holes and fit the wall plugs.
7. Fit the two 30mm fixing screws in the top holes leaving approximately 9mm of the screw protruding.
8. Fit the keyhole slots in the top of the siren over these screws and check that they form a neat fit with minimal movement. If necessary remove the siren and adjust the screws as required.

9. Remove the siren and fit the wall mounting plate in position using the two 25mm fixing screws.
10. Fit the siren to the wall ensuring that the keyhole slots are correctly fitted over the heads of the two top fixing screws and the lower fixing hole lines up with the wall plate.
11. Secure the Siren in place by fitting the lower fixing screw in the wall plate. Do not over tighten the screw as this could damage the thread.

### MAINTENANCE

The batteries in the siren should be replaced once every year to ensure the siren continues to act as a visual deterrent during both the day and night.

### DISPOSAL

At the end of their useful life the packaging, batteries and product should be disposed of via a suitable Recycling Centre. Do not dispose of with your normal household waste. **DO NOT BURN.**



### GUARANTEE

Novar ED&S (A Honeywell Company) undertakes to replace or repair at its discretion goods (excluding non rechargeable batteries) should they become defective within 2 years solely as a result of faulty materials and workmanship. Understandably if the product has not been installed, operated or maintained or maintained in accordance with the instructions, has not been used appropriately or if any attempt has been made to rectify, dismantle or alter the product in any way the guarantee will be invalidated.

The guarantee states Novar ED&S entire liability. It does not extend to cover consequential loss or damage or installation costs arising from the defective product. This guarantee does not in any way affect the statutory or other rights of the consumer.

If an item develops a fault, the product must be returned to the point of sale with:

1. Proof of purchase.
2. A full description of the fault.
3. All relevant batteries (disconnected).

Friedland is a trade mark of Novar ED&S.

### HELPLINE

If you have any problems with your alarm, please call the Helpline on:

# 0870 850 3015

(Lines open 9.00am to 5.00pm, Monday to Friday. Calls charged at service providers national rate).