

Friedland

6 Zone Wirefree Security Alarm Gold



Installation & Operating Manual

FOREWORD

All devices in this wirefree Alarm System are designed and manufactured to provide long reliable service. The system is designed for ease of installation using only conventional domestic tools. However, it is essential that the installer reads and fully understands the advice and procedures contained in this manual and plans the system before proceeding with the installation.

During installation, it is important that the procedures described in this manual are followed in sequence.

This manual should be retained in a safe place for future reference.

IMPORTANT: All devices, with the exception of the External Siren are suitable for mounting in dry interior locations only.

IMPORTANT:

LOCAL AUTHORITY REGULATIONS AND LEGISLATION

This alarm system should be installed and operated in accordance with the requirements of any current local and/or national regulations and legislation. We recommend that you contact your authority to obtain details of your area's requirements regarding intruder alarm installations.

For example in Belgium, the installation and use of an alarm system including notification by telephone (Voice Dialler) functionality and the optional use of an external siren is controlled by Belgium legislation "KB" of 19/06/2002.

DECLARATION

Novar ED&S hereby declares that this wirefree alarm system is in compliance with the essential requirements and other relevant provisions of the Radio and Telecommunications Terminal Equipment (R&TTE) directive, 1999/5/EC.

Tools and Equipment Required:

No.0 Philips Screwdriver	Bradawl
No.1 Philips Screwdriver	Drill
No.2 Philips Screwdriver	3mm Drill Bit
Small Spirit Level	5 & 6mm Masonry Drill Bits

DEVICE RANGE

The quoted range of the system devices (see component specification on rear cover) is measured in ideal conditions. Any solid object (e.g. walls, ceilings, reinforced PVC doors etc) placed between the transmitter and Receiver device will reduce the radio range.

The amount by which the range will be reduced is dependant upon the nature of the barrier.

For example:

Wall Type	Range Reduction
Dry-lined partition wall:	10 - 30%
Single layer brick wall:	20 - 40%
Double layer brick wall:	30 - 70%
Metal panel/radiator:	90 - 100%

Note: The effect on the range of multiple walls is cumulative, i.e. if there are 2 brick walls in the way, the range will be reduced by up to 40% by each wall.

SYSTEM SECURITY

This system has been designed to both detect intruders and act as a strong deterrent to would-be intruders when installed correctly.

We recommend that your Alarm is used in conjunction with good physical protection such as security window and door locks.

All units in the system are encoded to operate together using a 20 bit House Code.

The system is operated from one or more Remote Control Units and/or Keypads.

SAFETY

Always follow the manufacturers advice when using power tools; steps, ladders etc. and wear suitable protective equipment (e.g. safety goggles) when drilling holes etc.

Before drilling holes in walls, check for hidden electricity cables and water pipes, the use of a cable/pipe locator maybe advisable if in doubt.

When using ladders, ensure that they are positioned on a firm stable surface at the correct angle and suitably secured before use.

The use of ear defenders is advisable when working in close proximity to the Siren due to the high sound level produced by this device.

CONTENTS

KIT CONTENTS	4	Linking the Solar Siren to the Control Panel	21
INTRODUCTION AND OVERVIEW	5	Testing the Wirefree Solar Siren	21
System Arming	5	Mounting the Solar Siren on to the wall	21
Entry/Exit Delay	5	SPECTRA LIGHTENING RECEIVER	22
Zones	5	Linking the Control Panel to the Spectra	
Zone Lockout	5	Lightening Receiver	22
Tamper Protection	5	Spectra Lightening Test	22
Jamming Detection	6	EXTERNAL CONNECTIONS	23
Battery Monitoring	6	TESTING THE SYSTEM	24
User Access Code	6	FACTORY SETTINGS	25
PLANNING AND EXTENDING YOUR		Reset Factory Settings	25
ALARM SYSTEM	6	PROGRAMMING INSTRUCTIONS	26
Typical Installation	6	User Access Code	26
REMOTE CONTROL UNIT	8	Alarm Duration	26
General Information	8	Entry/Exit Delay	26
Configuring the Remote Control	8	Instant/Delay Zones	27
Testing the Remote Control	8	Entry/Exit Warning Tone	27
CONTROL PANEL	8	Part-Arm	27
Positioning the Control Panel	8	Zone Lockout	27
Installing and Configuring the Control Panel	9	Jamming Detection	28
Learning a New Remote Control/Keypad	10	Spectra Lightening Status	28
Testing the Control Panel and Remote Control	11	Spectra Lightening Time-On Period	28
PASSIVE INFRA-RED (PIR) MOVEMENT		Zone Operating Mode	28
DETECTORS	12	OPERATING INSTRUCTIONS	29
Positioning the PIR Detectors	12	Arming the System	29
Installing and Configuring the PIR Detectors	13	Part-Arming the System	29
Testing the PIR Detectors	14	Disarming the System	29
MAGNETIC CONTACT DETECTORS	14	Personal Attack (PA) Alarm	30
Positioning the Magnetic Contact Detectors	15	Device Tamper	30
Installing and Configuring the Magnetic		Fire Zone(s)	30
Contact Detectors	15	Siren Service Mode	30
Testing the Magnetic Contact Detectors	16	Siren Operating Mode	31
LEARNING ZONE DETECTORS	17	Battery Monitoring	31
LEARNING FIRE ZONES	18	Spectra Lightening	32
EXTERNAL SOLAR SIREN	19	MAINTENANCE	32
General Information	19	TROUBLE SHOOTING	34
Positioning the Solar Siren	19	EXTENDING YOUR ALARM SYSTEM	37
Installing and Configuring the Solar Siren	19	COMPONENT SPECIFICATION	40
Power-up of the Solar Siren	20		

KIT CONTENTS

The Alarm System should contain the following devices.

- 1 x Solar Siren
- 1 x Control Panel
- 1 x Remote Control
- 2 x PIR Movement Detectors
- 2 x Magnetic Contact Detectors

Also included:

- Installation & Operating Manual
- Fixing pack
- Batteries

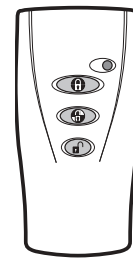

Remote Control

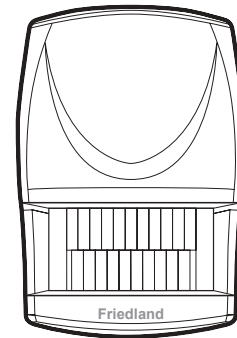

PIR Movement Detector

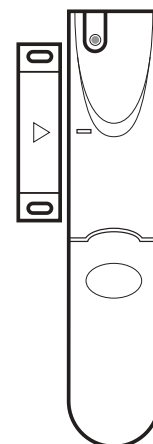

Magnetic Contact Detector

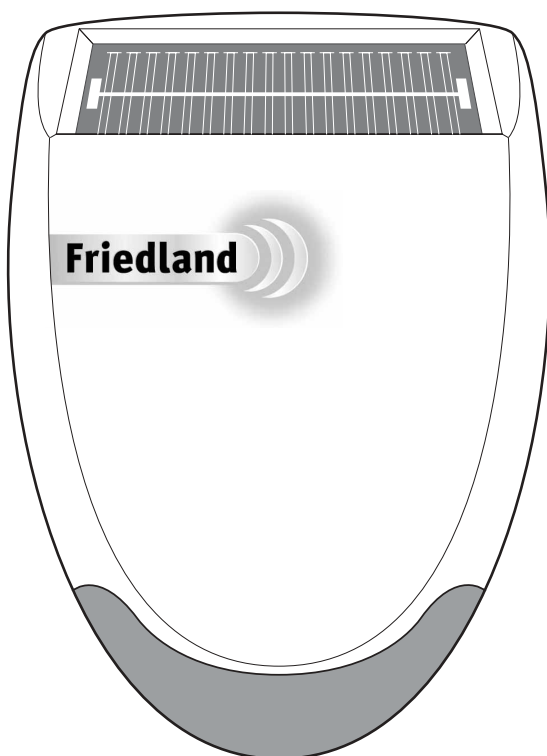

Solar Siren

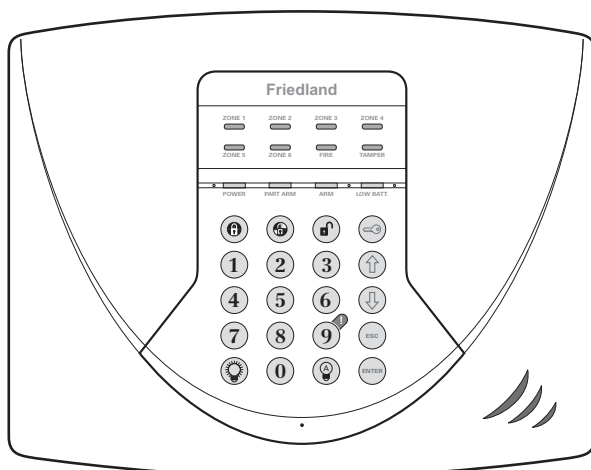

Control Panel

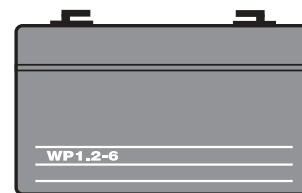

6V/1.2Ah Sealed lead acid battery
(supplied fitted in Siren)



9V PP3 Alkaline battery
(for Siren and PIR Detectors)



3V CR2032 Lithium Coin Cell
(for Remote Control and
Magnetic Contact Detectors)

INTRODUCTION AND OVERVIEW

SYSTEM ARMING

The system has a 'Full Arm' and a 'Part-Arm' facility. Full Arm will arm all zones while the 'Part-Arm' mode will only arm the zones that are selected and enabled for "Part-Arm".

For example:

The system could be configured so that during night time, 'Part-Arm' would arm only zones protecting the lower floor and outbuildings leaving the upper floor free for movement without triggering the alarm.

However, when the property is left unoccupied, the 'Full Arm' mode will arm all zones to protect the entire property, (i.e. upper and lower floors and outbuildings).

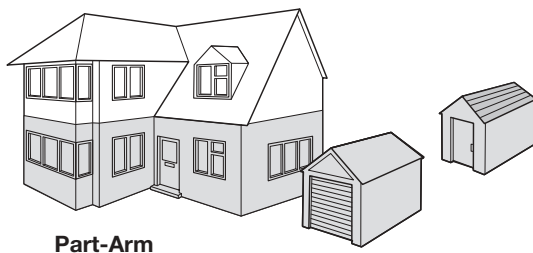
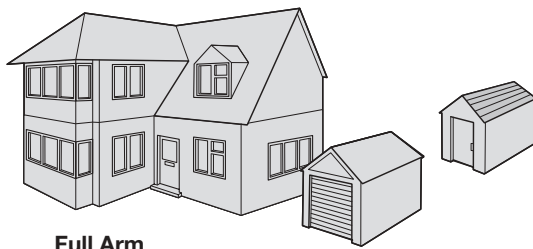

ENTRY/EXIT DELAY

Each zone can be programmed to be Armed in either Instant or Delay mode.

Usually the zone covering the main entrance door and the route to and from the Control Panel would be configured to Delay mode. This allows time for the user to exit the property after setting the system at the Control Panel or to Disarm the system before the alarm triggers when re-entering the property. The remaining zones would be configured as Instant allowing them to sound the alarm immediately a detector on a zone is triggered.

Delay Armed zones will not become fully armed until after the Entry/Exit delay period has ended. When a detector on a Delay Armed zone is triggered, an alarm condition will not be triggered until after the

Entry/Exit period has ended. If the system is not disarmed during the delay period, the alarm will sound when the delay period expires.

Instant Armed zones are immediately able to initiate an alarm as soon as the system begins to arm.

Note: To conserve power and maximise battery life the PIR Detector will only detect movement if there has been no movement detected within the previous 2 minutes. Consequently the PIR Detector will not become active until the protected area has been free from movement for at least 3 minutes.

ZONES

The system incorporates 6 wirefree alarm zones for the connection of the detectors used to independently monitor different areas of the property. In addition to standard intruder protection, each zone can also be configured to operate in alternative modes.

For example:

- '24-hour Intruder' mode provides 24 hour intruder protection for areas where continuous monitoring is required, (e.g. gun lockers).
- 'Fire' mode provides 24 hour monitoring of any Fire/Smoke detectors incorporated into the system.

ZONE LOCKOUT

If a detector on an active zone is triggered while the system is armed, the alarm will sound. After the programmed alarm duration has ended, the alarm will stop and the system will automatically reset. Subsequent detectors triggered will again trigger an alarm. If a single zone triggers an alarm more than 3 times then that zone will become 'Locked Out' and any further alarm signals from that zone will be ignored until the system is disarmed.

Note: The 'Zone Lockout' feature can be disabled if required (see page 27).

TAMPER PROTECTION

All system devices (except any Remote Control Units) incorporate Tamper protection features to protect against unauthorised attempts to interfere with the device.

Any attempt to remove the battery cover from any

device (except a Remote Control) or to remove the Solar Siren or Control Panel from the wall will trigger the alarm even if the system is Disarmed (unless the system is in Test or Program modes).

JAMMING DETECTION

In order to detect any attempts to illegally jam the radio channel used by your alarm system, a special jamming detection function is incorporated into the Control Panel. If this feature is enabled, an alarm will be triggered if the radio channel is jammed continuously for more than 30 seconds or if the system is jammed for more than 3 periods of 10 seconds in a 5 minute period.

The jamming detection circuit will constantly scan for jamming signals. However, it will also detect and could in extreme cases be triggered by radio signals from other radio equipment within range operating on the same frequency which would not interfere with the normal operation of your alarm.

If you are planning to operate the Jamming Detection feature we recommend that you wait at least 30 days before activating this feature to allow time for you to become familiar with the operation of your system.

When activating jamming detection the system should be monitored carefully for false jamming alarms for at least 2 weeks before leaving the Jamming Detection function permanently enabled.

BATTERY MONITORING

All devices powered by non-rechargeable batteries incorporate a battery level monitoring feature which will warn of a low battery status.

In addition the Control Panel will also indicate a low battery status on any PIR (Passive Infra-Red) or Magnetic Contact Detector on the system.

The batteries on any device indicating a low battery status should be replaced immediately.

USER ACCESS CODE

The Control Panel is the heart of the system and is where the system is programmed and operated from. A 4 digit code is used to ensure that only authorised people have access to the system. This is the User

access code and can be set to a code of your choice that only you and other authorised system users know.

PLANNING AND EXTENDING YOUR ALARM SYSTEM

Before attempting to install your Alarm System it is important to study your security requirements and plan your installation accordingly.

PIR Movement Detectors are used to protect the main areas of the property, (e.g. lounge, study, hallway and landing). Magnetic Contact Detectors are typically used to protect the main access points to the property, (e.g. front door, back door, patio doors etc). However, they can also be used to protect other vulnerable doors/ windows or access doors to important rooms.

TYPICAL INSTALLATION

The following example (right) shows a typical property incorporating the suggested positions for the External Siren, PIR and Magnetic Contact Detectors. Use this as a guide for your installation in conjunction with the detailed positioning requirements for each device provided in the appropriate installation sections in this manual for planning your intruder alarm system.

Typical Installation using only the detectors supplied:

1. Place the 1st Magnetic Contact Detector (configured on zone 1) on the front door.
2. Place the 1st PIR Detector (also configured on zone 1) in the hall covering the Control Panel and routes between downstairs rooms.
3. Place the 2nd Magnetic Contact Detector (configured on zone 2) on the back or Patio doors.
4. Place the 2nd PIR Detector either
 - i) downstairs in the main living room containing most valuables, (set on zone 3), or
 - ii) upstairs on the landing covering the access routes between bedrooms and the stairs, (set on zone 5). This will be inactive if Part-Arm is used.

The system may be expanded with additional detectors, Remote Controls and Keypads to provide even greater

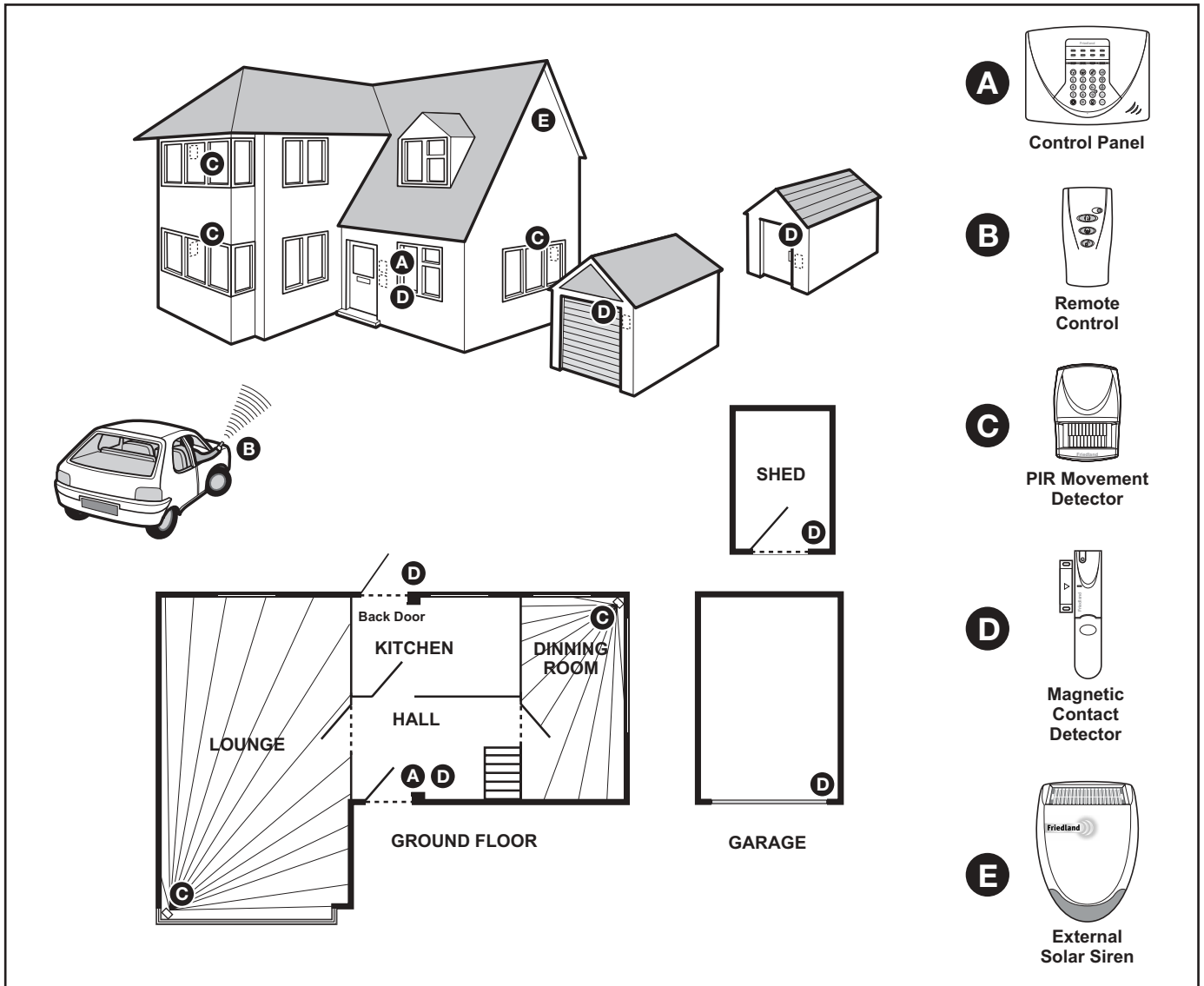

protection. However, the following rules should be followed:

- Any detectors covering the main door and the route to the Control Panel should be set on zone 1 only.
- Any detectors covering the remainder of the lower floor should be set on zones 2 to 4 only.
- Any detectors placed upstairs should be set on zones 5 or 6 only.

The pre-configured system defaults provide a basic functional system which will suit most installations, (i.e. a 2 floor house).

The systems factory settings are pre-configured to provide a basic functional system to suit most typical basic installations:

- The system has a 3 minute alarm duration.
- The Zone Lockout feature is ON so that if any single zone triggers an alarm more than 3 times,

alarm signals from that zone will be ignored until the system is next re-armed.

- Detectors on Zone 1 (typically the front door and hallway) will have a 30 second entry/exit delay period.
- Detectors on all other zones are configured as INSTANT, (i.e. they have no entry/exit delay).
- Part-Arm is configured to operate with detectors on zones 1 to 4 only.

Note: If you wish to change the system configuration away from the above example and factory settings and customise it to your own unique requirements or activate any of the more advanced system features then refer to the Programming section on page 26.

This manual also covers installation and operation for accessories, which may not be supplied with this alarm kit. When purchasing accessories, please refer to the manual supplied with the accessories for further information on these items.

REMOTE CONTROL UNIT

The Remote Control Unit(s) is used to Arm in either Instant-Arm or Delay-Arm modes and to Disarm the system.

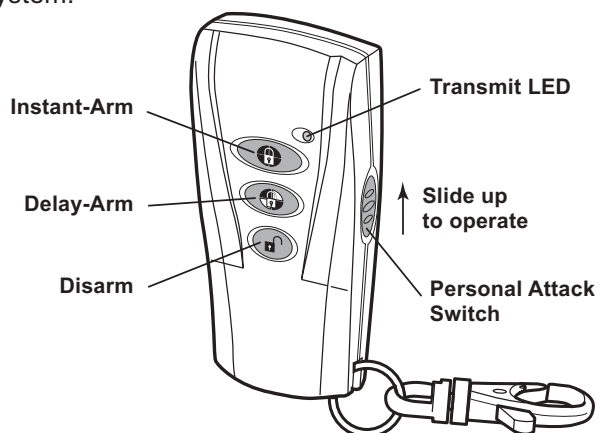

The Remote Control Unit also incorporates a Personal Attack (PA) switch. Activating the PA switch on the side of the Remote Control will immediately trigger an Alarm (unless the Control Panel is in Test or Program Modes) even if the system is disarmed. The alarm can be cancelled using the Remote Control by pressing the 'DISARM' button.

Up to a total of 6 Remote Controls and/or Keypad Units can be used with your system, providing they are all operated within effective radio range of the Siren.

The Remote Control is powered by a CR2032 type Lithium cell which under normal conditions will have an expected life of approximately 1 year. Under normal battery conditions the Transmit LED on the Remote Control will only illuminate when a button is pressed.

However, under low-battery conditions this LED will continue to flash after the button has been released. When this occurs the battery should be replaced as soon as possible.

CONFIGURING THE REMOTE CONTROL

1. Remove the rear cover by undoing the small screw on the rear of the Remote Control and keeping it safe for later.
2. Insert the battery under the clip ensuring that the + terminal faces upwards away from the Circuit Board.
3. Replace the rear cover and fixing screw. Do not over tighten the screw as this could damage the thread.

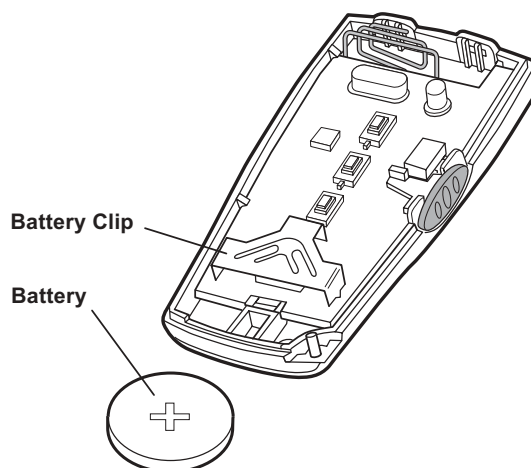

TESTING THE REMOTE CONTROL

4. Press the  button. The Transmit LED should illuminate while the button is pressed and extinguish within 1 second of releasing the button.
5. Pressing any button on the Remote Control will illuminate the Transmit LED as before to check that it is functioning correctly.

CONTROL PANEL

POSITIONING THE CONTROL PANEL

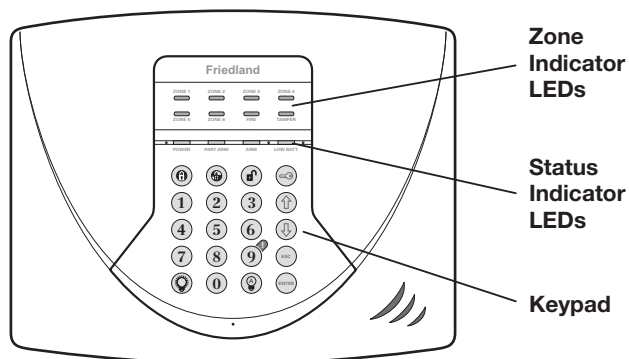

When choosing a suitable location for the Control Panel, the following points should be considered.

1. The Control Panel should be located in a position out of sight of potential intruders and in a safe location, but easily accessible for system operation and leaving and entering the house within the set time period.
2. The Control Panel should be mounted on a sound flat surface to ensure that the rear tamper switch on the Control Panel is closed when the Panel is

mounted. The Control Panel should be mounted at a convenient height of between 1.5 and 2 metres and in a position where it will be seen each day.

Note: If small children are in the household, a further consideration should be given to keeping the unit out of their reach.

3. It is recommended that the Control Panel should be positioned such that the Exit/Entry tone (emitted by the Control Panel) can be heard from outside the property.
4. The Control Panel should be mounted within a protected area so that any intruder cannot reach the Control Panel without opening a protected door or passing through an area protected by a PIR Detector when the system is armed.
5. **The Control Panel must be located within reach of a mains socket.**
6. **DO NOT fix the Control Panel onto or very close to metalwork (i.e. radiators, water pipes, etc) as this could affect the radio range of the device.**

INSTALLING AND CONFIGURING THE CONTROL PANEL

1. Undo the two cover fixing screws on top of the panel and open the cover. The cover is hinged along the bottom edge.
2. Unclip and remove the two back-up batteries on either side of the panel.
3. Hold the Control Panel in position on the wall and mark the positions of the four fixing holes. Remove the panel, drill four 5mm holes and fit the 22mm wall plugs.

Note: The wall plugs supplied with the product are not suitable for plasterboard walls. If mounting the Control Panel onto plasterboard use appropriate wall plugs.

Do not drill the fixing holes with the Control Panel in position; as the resulting dust and vibration may damage the Control Panel's internal components and invalidate the guarantee.

4. Fit two 18mm No.4 screws into the top holes until 3mm protrudes from the wall face and hang the

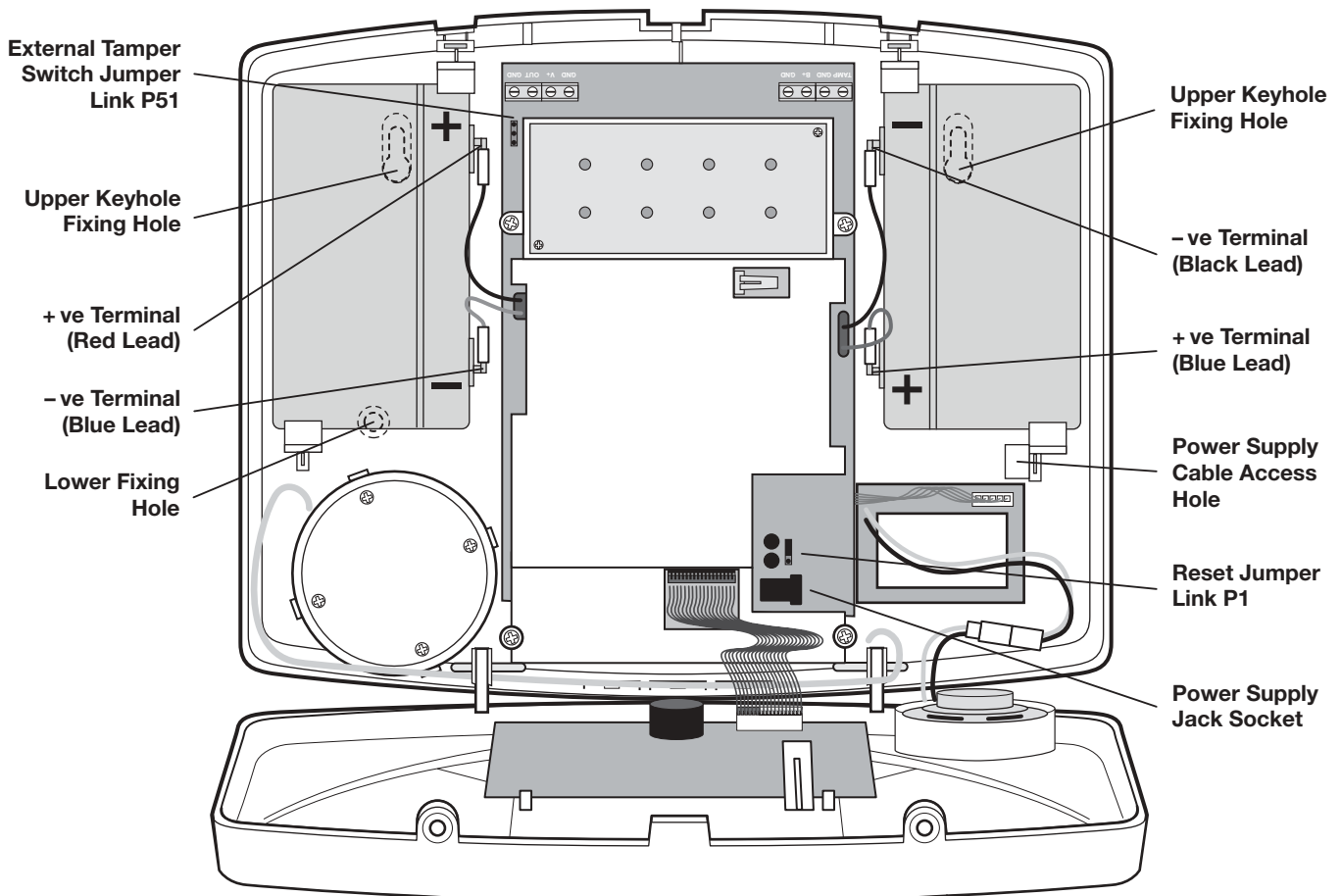

Inside View of Control Panel

Control Panel over these screws using the two keyhole slots in the top corners of the panel casing.

- Route the cable from the Power Supply Adaptor up behind and on the right hand side of the Control Panel and connect the plug to the DC power socket in the panel. Ensuring that the cable is not trapped between the panel and the wall.
- Fix the Control Panel to the wall using two 18mm No.4 screws in the lower two fixing holes in the Control Panel and tighten the upper fixing screws until they just grip the casing. Do not over-tighten the screws as this could damage or distort the casing.
- Ensure that the Reset Jumper Link (P1) and the External Tamper Switch Jumper Link (P51) are set in the OFF position.

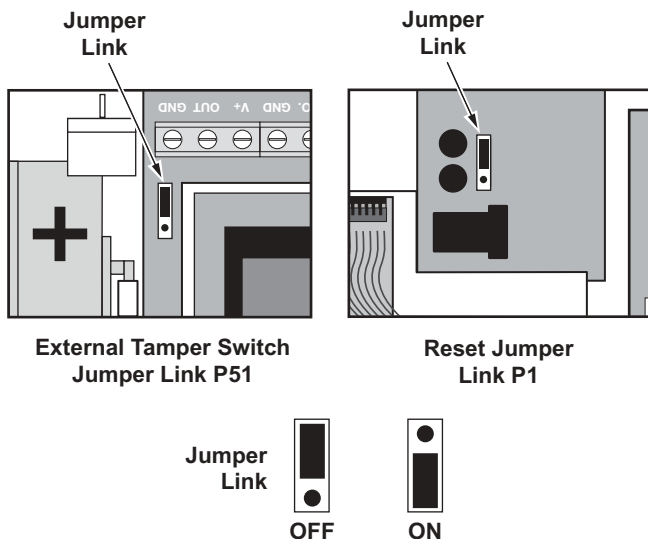

- Connect battery leads to both back-up batteries and refit batteries.







LEFT Battery: Red lead to the Red (+) battery terminal
Blue lead to the Black (-) battery terminal

RIGHT Battery: Blue lead to the Red (+) battery terminal
Black lead to the Black (-) battery terminal

IMPORTANT: Take care when connecting battery leads to the batteries as connecting incorrectly could damage the batteries or the Control Panel.

Note: The Power LED may flash to indicate that the unit is being operated from the back-up batteries and that mains supply is not present.

- Close the lid of the Control Panel and fasten the cover fixing screws.
- Plug in and switch ON the Power Supply Adaptor, (the Power LED should illuminate).

Note: If the Control Panel Tamper alarm sounds during the installation reset the alarm by pressing  ,     ,  on the Control Panel.

User Access Code

IMPORTANT: The keys must be pressed firmly and within 3 seconds of each other. If you make a mistake, press  and start the sequence again.

LEARNING A NEW REMOTE CONTROL/KEYPAD

Note: Up to a total of 6 Remote Controls and/or Keypad Units can be linked to the system.

To link a new Remote Control/Keypad to the Control Panel:

Place the Control Unit into Learn mode. With the system in Standby press



The Arm and Part-Arm LEDs will illuminate and all Zone, Fire and Tamper LEDs will flash together.

- Press    on the Control Panel.

The Tamper LED will flash continuously to indicate the system is in device learn mode.

The current number of Remote Controls/Keypads already linked into the system will be indicated on the zone LEDs. For example if there are three Remotes/Keypad linked then zone LEDs 1, 2 and 3 will be illuminated.

The panel will now listen for valid signals from new remote controls or keypads.

Note: The Panel will remain in Learn Mode for 30s. If a valid signal is not received from a new Remote Control or Keypad within 30s it will automatically exit Learn Mode and return to the top level of Program Mode.

- Press the  button on the new Remote Control or

Press     , 
Keypad Access Code

on the Remote Keypad.

If the Remote Control/Keypad is new and not already linked the panel will produce a two short beeps and the next available zone LED will start flashing, (once every second).

Note: If the Remote Control/Keypad is already linked to the control panel or if there are already the maximum 6 Remote Controls/Keypads linked to the control panel then the panel will produce a single long beep and the signal from the new Remote Control will be ignored.

- Confirm the device ID code by pressing the  button on the same new Remote Control within 15 seconds or



using the Keypad, confirm by pressing

    , 
Keypad Access Code

The panel will produce three short beeps and the zone LED will stop flashing and remain ON.

Note: If the confirmation signal is not received within 15s the LED will stop flashing and turn off. The panel will exit to the top level of learn mode without saving any changes. The learning process will need to started again to link the new device.

The ID code of the new Remote Control/Keypad is now stored in memory ready for saving.





- Press  to save new settings and return to step1 or press  to exit without saving.
- If after adding a remote, no more remotes require linking then press  to exit Learn mode.

To delete all linked Remote Controls/Keypads from the Control Panel:

- Place the Control Unit into Learn mode. With the system in Standby press

 ,     , 
User Access Code



The Arm and Part-Arm LEDs will illuminate and all Zone, Fire and Tamper LEDs will flash together.

- Press    on the Control Panel.
- Press 

All illuminated zone LEDs indicating linked devices will start flashing, (once every second).
- Press  again within 15 seconds to confirm and erase the device links.

The flashing zone LEDs will extinguish.

Note: If the erase is not confirmed within 15s the LEDs will stop flashing and remain illuminated. All links will remain intact and will not be erased.

- Press  to save new settings and return to step1 or press  to exit without saving.
- If after deleting a remote, no more remotes require deleting then press  to exit Learn mode.

TESTING THE CONTROL PANEL AND REMOTE CONTROL

- Arm the Control Panel by pressing the  button on the Remote Control.

The Zone LED will illuminate for a few seconds to indicate which zones are being armed. As the entry/exit delay expires the Control Panel will slowly beep and the Arm LED will flash. Towards the end of the delay the beep rate will increase. When the entry/exit delay is completed the beeping will stop and the Arm LED will stop flashing and be constantly illuminated.

- Disarm the system by pressing the button on the Remote Control.

The Control Panel will beep twice and the Arm LED will turn OFF.



3. Activate the Personal Attack switch on the Remote Control.

The Control Panel alarm will sound and all Zone/Fire/Tamper LEDs will flash.

4. Disarm the system by pressing the  button on the Remote Control.

The Control Panel alarm will stop. The LEDs will continue to flash.

5. Press  on the Control Panel to return to Standby and cancel any warning LEDs.

6. Test the range of the Remote Control by pressing the  button on the Remote Control from in and around the property and from all locations where you plan to install detectors. Check that the Control Panel acknowledges the signal from the Remote Control by beeping twice each time the  button is pressed.

PASSIVE INFRA-RED (PIR) MOVEMENT DETECTORS

PIR Detectors detect movement in a protected area by detecting changes in infra-red radiation levels caused for example when a person moves within or across the PIR's detection pattern. If movement is detected an alarm will be triggered, (if the system is armed). PIR Detectors will also detect animals, so ensure that pets are not permitted access to areas fitted with PIR Detectors when the system is armed.

The Detector incorporates an anti-tamper protection feature to protect against attempts to interfere with the device. If the battery cover is removed, an alarm will immediately occur at any time, (unless the system is in Service or Test Modes).

The PIR Detector also incorporates a sensitivity adjustment feature to compensate for situations where the detector may be triggered by environmental changes, (e.g. air temperature, etc).

To conserve power and maximise battery life the PIR Detector will only detect movement if there has been no movement detected within the previous 2 minutes, (this is known as the detectors sleep period).

The PIR Detector is powered by a 9V PP3 Alkaline battery which under normal conditions will have an expected life of approximately 1 year. When the battery level drops, with the PIR in normal operation mode and the battery cover fitted, the LED behind the detection window will flash. When this occurs the battery should be replaced as soon as possible. (**Note:** in normal operation, the LED behind the lens will not flash on detection of movement).

Up to a total of 12 detectors (PIR Movement Detectors and/or Magnetic Contact Detectors) can be used with the system, providing they are all mounted within effective radio range of the Siren.

POSITIONING THE PIR DETECTORS

The recommended position for a PIR Detector is in the corner of a room mounted at a height between 2 and 2.5 metres. At this height, the detector will have a maximum range of up to 12 metres with a field of view of 110°.

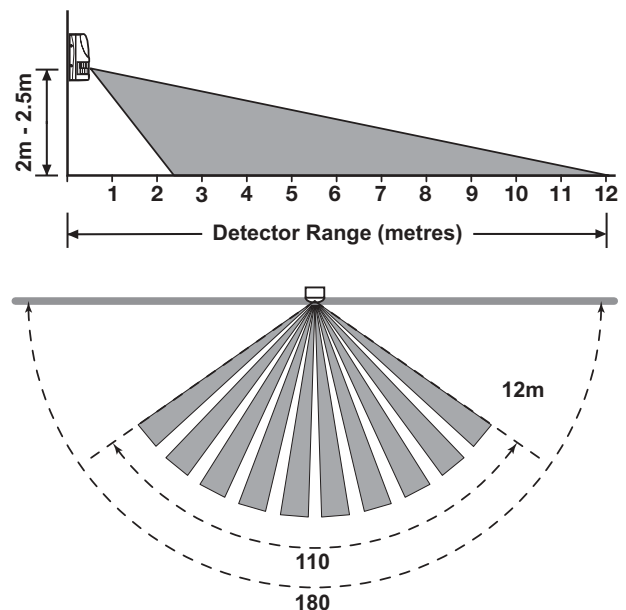

When deciding upon the mounting position for the detector the following points should be considered to ensure trouble free operation:

1. Do not position the Detector facing a window or where it is exposed to or facing direct sunlight. PIR Detectors are not suitable for use in conservatories.
2. Do not position the Detector where it is exposed to draughts.
3. **Do not position the Detector directly above a heat source, (e.g. fire, radiator, boiler, etc).**

4. Where possible, mount the Detector in the corner of the room so that the logical path of an intruder would cut across the fan detection pattern. PIR Detectors respond more effectively to movement across the device than to movement directly towards it.
5. Do not position the Detector in a position where it is subject to excessive vibration.
6. Ensure that the position selected for the PIR Detector is within effective range of the Siren.
7. **Do not fix the PIR Detector onto or very close to metalwork (i.e. radiators, water pipes, etc) as this could affect the radio range of the device.**

Note: When the system is Armed, pets should not be allowed into an area protected by a PIR Detector as their movement could be detected and trigger an alarm.

INSTALLING AND CONFIGURING THE PIR DETECTORS

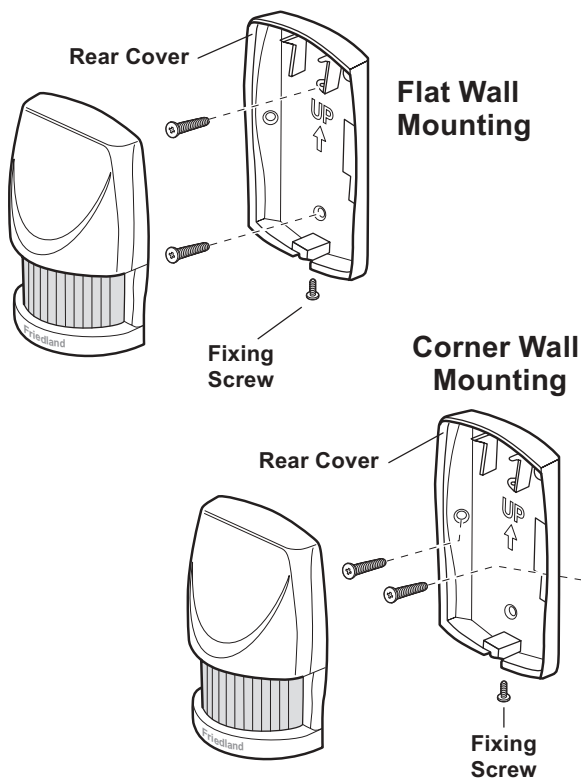

1. Undo and remove the fixing screw from the bottom edge of the PIR Detector, (keep the screw safe for later). Carefully pull the bottom edge of the detector away from the rear cover and then slide down to release the top clips.

2. Carefully drill out the required mounting holes in the rear cover using a 3mm drill according to whether the unit is being mounted in a corner or against a flat wall.
3. Using the rear cover as a template, mark the positions of the fixing holes on the wall.
4. Fix the rear cover to the wall using the two 18mm No.4 screws and 22mm wall plugs, (a 5mm hole will be required for the wall plugs). Do not over-tighten the screws as this may distort or damage the cover.

Note: The wall plugs supplied with the product are not suitable for plasterboard walls, if mounting the Detector onto plasterboard use appropriate wall plugs.

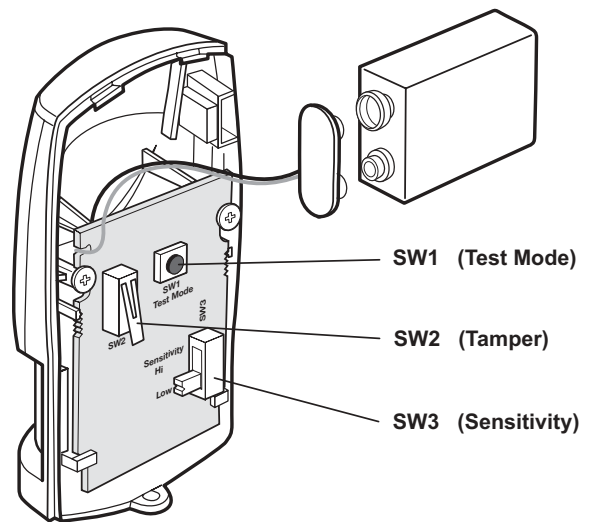

5. To select the required sensitivity, set switch SW3 as follows:

UP HIGH sensitivity
DOWN LOW sensitivity

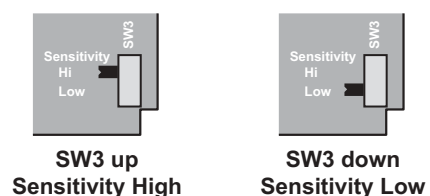

Note: The recommended setting is HIGH. However, in cases of extreme environmental problems or if unexplained false alarms are experienced, it may be necessary to set the sensitivity to LOW. Setting the device to LOW sensitivity will require a greater amount of movement in order to trigger the device.

- Connect the PP3 Alkaline battery to the battery clip. The LED behind the lens will rapidly flash for approximately 2-3 minutes until the PIR has stabilised. The LED will then stop flashing and turn OFF.

in order to conserve power and maximise battery life the PIR Detector will only detect movement if there has been no movement detected within the previous 2 minutes.

TESTING THE PIR DETECTORS

- Ensure that the LED indicator has stopped flashing rapidly.
- The 'Test Mode' button (SW1) is used to put the PIR Detector into Walk Test mode, which overrides the 2 minute sleep period and allows the operation of the detector to be checked during installation. Press and hold the button for 2 seconds to activate test mode for a fixed 5 minute after which it will automatically revert to normal operation. On initial installation the detector should be configured into Walk Test ready for testing, (i.e. Pressing down SW1 for 2 seconds).

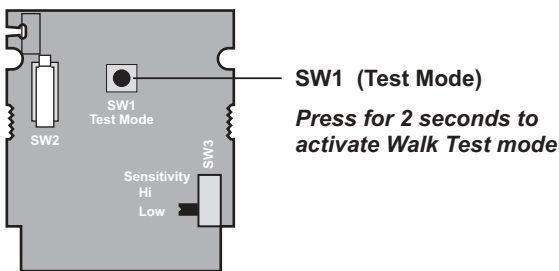

- Refit the PIR Detector to the rear cover by offering the detector up to the rear cover and locate the clips in the top edge into the rear cover. Push the lower edge of the detector into place and refit the fixing screw in the bottom edge of the PIR to secure in position. Do not over-tighten the screws as this may damage the casing.
- Walk into and move slowly around the protected area within the 5 minutes of pressing SW1. Each time the detector senses movement the LED indicator behind the lens will flash.

IMPORTANT: In normal operation, the LED indicator behind the detector lens will not flash on movement detection, (unless the battery is low).

When the detector is fully installed, i.e. battery cover fitted and in operating mode;

- To allow the Control Panel to learn the PIR Detector's ID code, remove the Detector from its cover again and see **LEARNING ZONE DETECTORS** on page 17.
- Refit the the Detector to the cover on the wall.

MAGNETIC CONTACT DETECTORS

The Magnetic Contact Set comprises of two parts; a Detector and a Magnet. They are designed to be fitted to either doors or windows with the Magnet mounted on the opening part of the door/window and the Detector mounted to the frame.

When the protected door or window is opened and the Magnet is moved away from the Detector an alarm will be triggered if the system is armed, (unless the Siren is in Service Mode).

The Magnetic Contact Detector has the facility to connect an additional wired Magnetic Contact. This must be of a normally closed contact type with the contact being opened in order to generate an alarm condition.

The Magnetic Contact Detector is powered by two CR2032 type Lithium cells which under normal conditions will have an expected life of approximately 1 year. Under normal battery conditions the LED on the Detector will not illuminate when the Detector is triggered, (unless the detector is in test mode with the battery cover removed). However, under low battery conditions this LED will be illuminated for approximately 1 second when the detector is triggered. When this occurs the batteries should be replaced as soon as possible.

Up to a total of 12 detectors (Magnetic Contact Detectors and/or PIR Movement Detectors) can be used with the system, providing they are all mounted within effective radio range of the Siren.

POSITIONING THE MAGNETIC CONTACT DETECTORS

The Magnetic Contact Detector is suitable for mounting in dry interior locations only.

Decide which doors and windows are to be protected by fitting Magnetic Contact Detectors, (usually the front and back doors as a minimum will have Magnetic Contact Detectors fitted). However additional detectors may be fitted where required to other more vulnerable doors or windows, (e.g. garage, patio/conservatory doors etc).

Ensure that the position selected for the Magnetic Contact Detector is within effective range of the Siren.

Do not fix the Detector onto or very close to metalwork (i.e. radiators, water pipes, etc) as this could affect the radio range of the device.

On PVC door/window frames, it may be necessary to space the Detector and Magnet away from the metal surface using a plastic or wooden spacer to achieve the necessary radio range.

INSTALLING AND CONFIGURING THE MAGNETIC CONTACT DETECTORS

Note: If adding a Magnetic Contact Detector to an installed system, ensure that the Siren is in Service Mode before commencing installation, (see page 19). Remember to switch the Siren back to Operating Mode after installation is complete, (see page 19).

1. Remove the battery cover by sliding and lifting it off. (DO NOT use a screwdriver to lever it off).

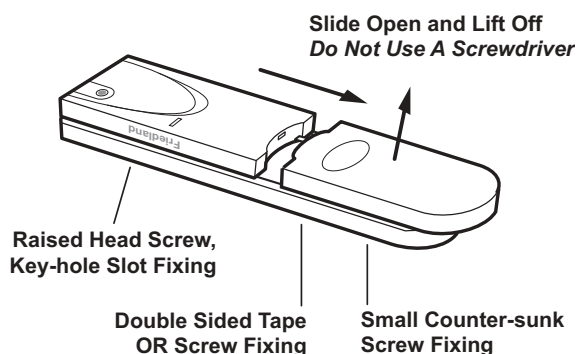

2. Slide the **two** batteries supplied into the battery holder, ensuring that the **+** side is uppermost on each battery as it is installed.

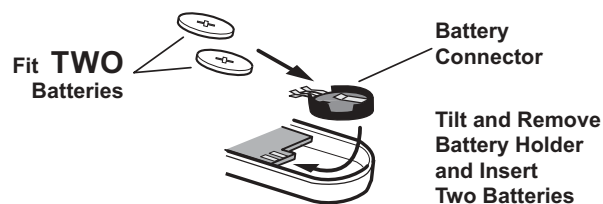

3. If necessary, refit the battery holder into the detector ensuring that the spring clip connectors slide onto either side of the circuit board.

The Detector should be mounted on the fixed part of the frame and the magnet on the opening part.

The Detector and Magnet should be mounted using the double sided adhesive pads or screws provided.

Note: If mounting the device using the adhesive pads, ensure that the mounting surfaces are clean and dry before mounting.

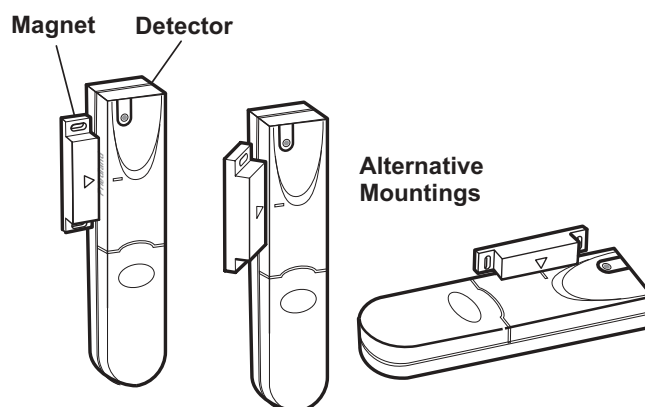

4. If fixing the detector with screws first remove the battery holder by carefully tilting up the end and pulling away from the printed circuit board (PCB).

The top of the Detector is secured by hanging the keyhole slot over the head of the 10mm pan head screw. The bottom of the Detector is secured using the 12mm counter-sunk head screw fitted within the battery compartment. Carefully drill out the centre of the fixing screw hole in the battery compartment using a 3mm drill. Fit the Magnet using the two 15mm fixing screws. Do not over-tighten the screws as this may distort or damage the casing.

5. If an additional wired Magnetic Contact is required, this should be wired to the terminal block provided in the battery compartment.

The wired contact should be connected using a maximum length of 1.5 metres of any of the following:

- 6 core alarm cable
- 2 core bell wire (6 x 0.2mm minimum)
- 2 core 24AWG wire

A cable entry cut-out is provided beside the terminal block in the battery cover.

7. Switch SW3 is used to enable/disable the internal/external wired magnetic contact.

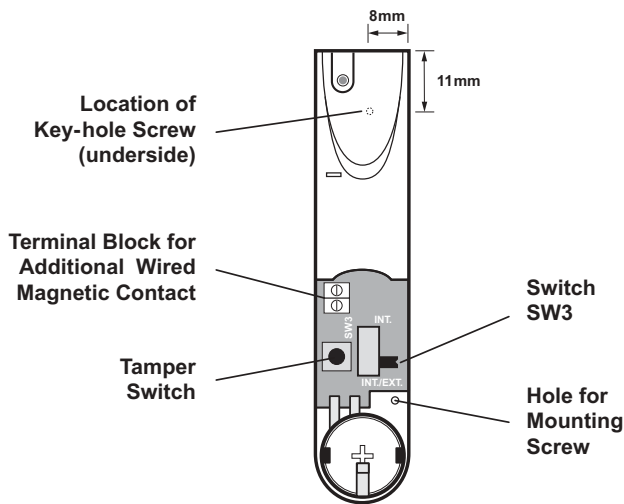

Position of SW3	Function
INT.	Internal Contact ON
INT./EXT.	Internal and External Contacts ON

8. Set the magnetic contact detector by setting the position of the switch (SW3).

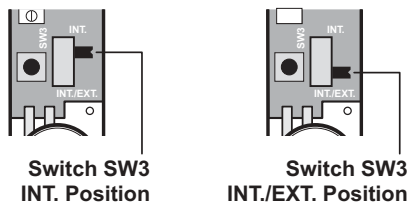

If setting to the INT. position, only the internal contact will be active. When two contacts are in use for internal and external connection simultaneously (INT./EXT. position), only one activation will be counted if one of the contacts is opened. If one contact is left open and the other closed contact is opened then an activation will be counted.

If using external contacts wired to the Detector, set to the bottom position.

IMPORTANT: If not using external contacts, set to the INT. position for the Detector to operate correctly.

9. Refit the battery cover.

TESTING MAGNETIC CONTACT DETECTOR

10. Remove battery cover to activate the tamper switch.

As the button is released the LED indicator will illuminate for approximately 1 second to show that the tamper switch has been triggered and a signal is being transmitted.

11. Open the door/window to remove the Magnet from the Detector.

As the Magnet is moved away from the Detector the LED indicator will illuminate for approximately 1 second to show that the Detector has been triggered and a signal is being transmitted.

Note: It does not matter if the LED indicator illuminates as the magnet is brought towards the detector.

IMPORTANT: With the battery cover fitted the LED indicator will not flash when the door / window is opened, (unless the battery is low).

12. In order to communicate with the Siren, the ID code of the Detector needs to be learned by the Siren. By pressing the tamper switch either located adjacent to the PCB or the rear cover of the Detector will emit the ID code subject to the Siren being placed in Learn Mode. Refer to Adding a new PIR/Magnetic Door/Window Contact Detector to the Siren opposite.

13. Refit the battery cover.

LEARNING ZONE DETECTORS

Note: A maximum of 3 PIR or MAG detectors can be linked to each alarm zone. A detector cannot be linked to more than one zone.

Place the Control Panel into Learn mode as follows:

With the system in Standby press



The Arm and Part-Arm LEDs will illuminate and all Zone, Fire and tamper LEDs will flash together.

1. To add/delete detectors on zone 1 press

and follow the process below

or for zone 2-6:

For zone 2 press and follow the process below.

For zone 3 press and follow the process below.

For zone 4 press and follow the process below.

For zone 5 press and follow the process below.

For zone 6 press and follow the process below.

The Tamper LED will flash continuously to indicate the system is in device learn mode

The current number of PIR/MAG Detectors already linked into zone 1/2/3/4/5 or 6 will be indicated on the zone LEDs. For example if there are two detectors linked, then zone LEDs 1 and 2 will be illuminated.

The panel will now listen for valid signals from new PIR or MAG detectors to link to the zone.

Note: The Panel will remain in Learn Mode for 30s. If a valid signal is not received from a PIR/MAG within 30s it will automatically exit Learn Mode and return to the top level of Program Mode..

To link a new PIR/MAG Detector to the Control Panel:

2. Activate the Tamper Switch on the new PIR/MAG detector.

If the detector is new and not already linked on **any** security zone the panel will produce two short beeps and the next available zone LED will start flashing, (once every second).

Note: If the detector is already linked to the control panel (on any zone) or if there are already the maximum 3 detectors linked to the specific alarm zone then the panel will produce a single long beep received signal from the detector will be ignored.

3. Confirm the new device ID code activating the Tamper Switch on the same new PIR/MAG detector within 15 seconds.

The panel will produce three short beeps and the zone LED will stop flashing and remain ON.

Note: If the confirmation signal is not received within 15s the flashing LED will stop flashing and turn off. The panel will exit to the top level of learn mode without saving any changes. The learning process will need to start again to learn the new device into memory.

The ID code of the new PIR/MAG detector is now stored in memory ready for saving.

4. Press to save new settings and return to step1 or press to exit without saving.
5. If after adding a detector, no more detectors require adding, then press to exit Learn mode.

To delete linked PIR/MAG Detectors from a zone on the Control Panel:



1. Follow step 1 in **Learn mode** if not already entered.
2. Press

All illuminated zone LEDs indicating linked devices will start flashing, (once every second).

- Press  again within 15 seconds to confirm and erase the device links.

The flashing zone LEDs will extinguish.

Note: If the erase is not confirmed within 15s the LEDs will stop flashing and remain illuminated. All links will remain intact and will not be erased.

- Press  to save new settings and return to step1 or press  to exit without saving.
- If after adding a detector, no more detectors require adding, then press  to exit Learn mode.

LEARNING FIRE ZONES

A maximum of 3 Smoke detectors can be linked to the dedicated Fire zone.

- Place the Control Panel into **Learn mode** as follows:

With the system in Standby press



The Arm and Part-Arm LEDs will illuminate and all Zone, Fire and tamper LEDs will flash together.

- Press   

The Tamper LED will flash continuously to indicate the system is in device learn mode.

The current number of Smoke Detectors already linked into the Fire zone will be indicated on the zone LEDs. For example if there are two smoke detectors linked, then zone LEDs 1 and 2 will be illuminated.

The panel will now listen for valid signals from new Smoke Detectors to link to the Fire zone.

Notes:

- PIR or MAG detectors cannot be added to the Fire zone and the system will prevent this.
- The Panel will remain in Learn Mode for 30s. If a valid signal is not received from a Smoke Detector within 30s it will automatically exit Learn Mode and return to the top level of Program Mode.

To link a new Smoke Detector to the Control Panel:

- Activate the Smoke detector via the test button.

If the detector is new and not already linked on the fire zone the panel will produce a two short beeps and the next available zone LED will start flashing, (once every second).

Notes:



- If the smoke detector is already linked to the control panel or if there are already the maximum 3 smoke detectors linked to the fire zone then the panel will produce a single long beep received signal from remote control will be ignored.
- PIR or MAG detectors cannot be linked to the Fire zone and the system will prevent this.

- Confirm the new device ID code activating the same new smoke detector via the test button within 15 seconds.

The panel will produce three short beeps and the zone LED will stop flashing and remain ON.

Note: If the confirmation signal is not received within 15s the flashing LED will stop flashing and turn off. The panel will exit to the top level of learn mode without saving any changes. The learning process will need to started again to learn the new device into memory.

The ID code of the new Smoke detector is now stored in memory ready for saving.

- Press  to save new settings and exit or
- Press  to exit without saving.

To delete all linked Smoke Detectors from the Control Panel:



- Press 

All illuminated zone LEDs indicating linked devices will start flashing, (once every second).

- Press  again within 15s to confirm and erase the device links.

The flashing zone LEDs will extinguish.

Note: *If the erase is not confirmed within 15s the LEDs will stop flashing and remain illuminated. All links will remain intact and will not be erased.*

9. Press  to save new settings and exit or
10. Press  to exit without saving.

EXTERNAL SOLAR SIREN

The Siren is encapsulated within a tough polycarbonate housing that also provides full protection against adverse weather conditions.

An LED indicator unit is built into the Siren to act as a visible deterrent and indication that the system is active. The LEDs will slowly and alternately flash whether the system is Armed or Disarmed. When an alarm occurs the LEDs will flash rapidly together.

An integral tamper switch provides additional security protection to the Siren and will immediately trigger an alarm should any unauthorised attempt be made to interfere with and remove the Siren cover.

The Siren is powered by a rechargeable sealed lead acid battery. A solar panel mounted on the top of the housing charges the battery during daylight hours. During darkness, only a small amount of energy is required to operate the Siren unit. A 9V Alkaline PP3 battery is supplied to boost the initial power to the unit when the system is first activated until the solar panel charges the main battery. (This battery is only designed to last for a short period until the main rechargeable battery has obtained sufficient charge). It does not need to be replaced.

The Siren unit incorporates the installation's Jamming Detection system which will (if activated) generate an alarm if any attempt is made to continuously jam the radio channel used for the system.

POSITIONING THE SOLAR SIREN

The Siren should be located as high as possible in a prominent position on an external wall so that it can be easily seen and heard. The Siren should be mounted on a sound flat surface so that the rear tamper switch is not activated when mounted.

Ensure that the tamper switch does not fall into the recess between brick courses as this could prevent the switch from closing and give a permanent tamper signal.

Shadows cast by neighbouring walls, trees and roof overhangs should also be avoided. If the Siren is to be mounted below the eaves, it should be positioned a distance of at least twice the depth of the eaves overhang below the eaves. Remember that in winter the sun is lower in the sky and you should avoid winter shadows where possible.

The Solar Siren contains a sophisticated radio receiver. However, reception of radio signals can be affected by the presence of metallic objects within the vicinity of the Siren. It is therefore important to mount the Siren a minimum distance of 1 metre away from any external or internal metalwork, (i.e. drainpipes, gutters, radiators, mirrors etc). Be especially aware of radiators mounted on the inside wall behind possible locations for the Siren.

Ensure that the position selected for the Siren is within effective range of the Keypad and all detectors.

INSTALLING AND CONFIGURING THE SOLAR SIREN

Ensure that the system is in Test Mode. Press



The Arm and Part-Arm LEDs will flash

1. Working on a table, undo the two battery cover fixing screws and remove the battery cover.
2. Under the cover you will also find a row of 5 DIP Switches labelled SW3 and a "LEARN" button.

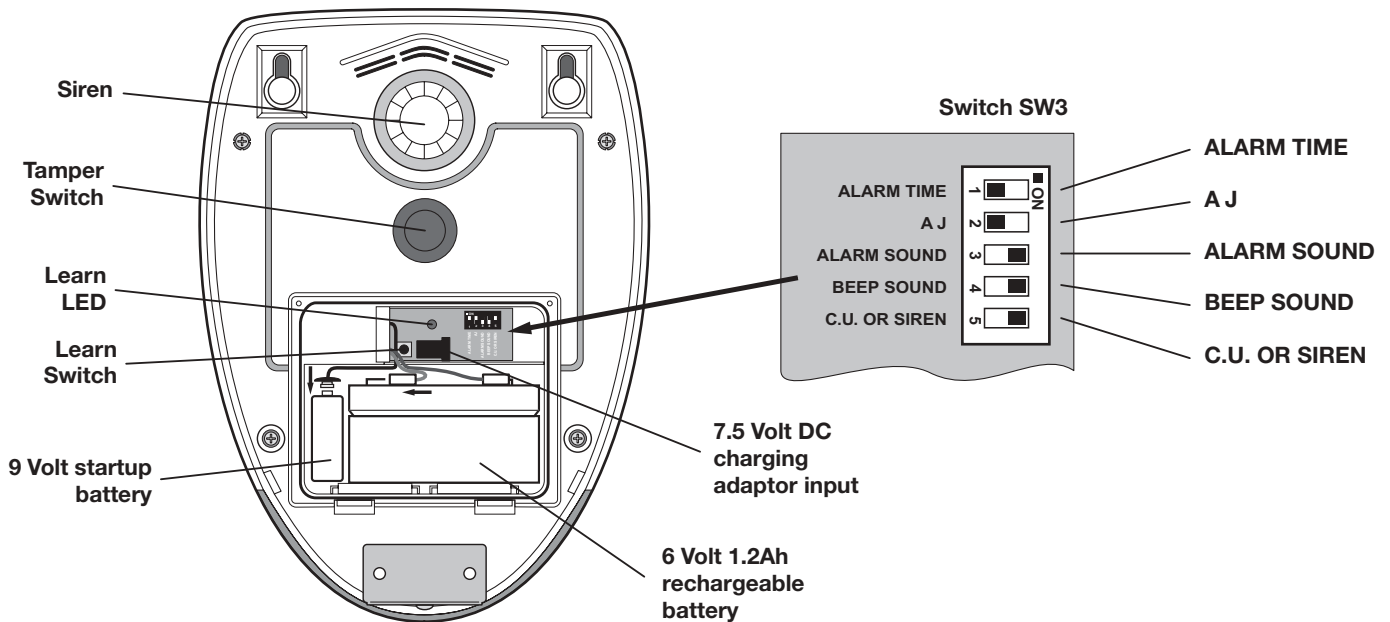

- Ensure that DIP switch 5 of SW3 on the LED indicator board is set to **OFF** ("SIREN") for use with this alarm system.

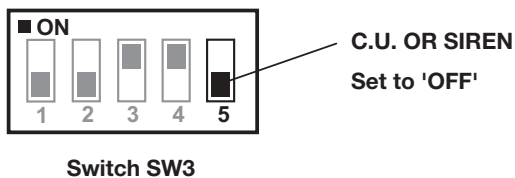

- DIP switch 1 marked "**ALARM TIME**" is used to limit the maximum period for which the external siren will sound before it will be automatically shut down, (even if the Control Panel is still in alarm):

ON	3 minutes
OFF	1 minute

- DIP switch 2 marked "**AJ**" controls the anti-jamming detection facility in the siren:

ON	Jamming Detection enabled
OFF	Jamming Detection disabled

- DIP switch 3 marked "**ALARM SOUND**" if OFF will prevent the siren from sounding during an alarm, (this will not affect the warning beeps):

ON	Siren enabled
OFF	Siren disabled

- The Solar Siren will acknowledge signals from the Remote Control, Keypad and Control Panel by beeping and flashing the LEDs. It is possible to disable these acknowledgement beeps DIP switch 4 marked "**BEEP SOUND**".

ON	Beeps enabled
OFF	Beeps disabled

- Now see Power-Up of the Solar Siren.

POWER-UP OF THE SOLAR SIREN

Note: The use of ear defenders is advisable when working in close proximity to the Siren due to the high sound level produced by this device when triggered. When the system is first installed, it will automatically power up in Service Mode. It cannot be switched out of Service mode and into Operating mode until at least one Remote Control or Keypad is link to it.

- Connect the rechargeable battery to the battery leads. Connect the Red lead to the Red (+ve) terminal and the Black lead to the Black (-ve) terminal.

Connect the 9V 6LR61 (PP3) power-up battery to the battery clip.

- Press the tamper switch, both indicator LEDs will flash together several times. The LEDs will then continue to flash alternately every 5 seconds thereafter to indicate that the Siren is functioning.

- If fitted remove the protective film covering the Solar Panel.

IMPORTANT: Once the batteries have been connected, the Siren will be operational and it is important that the solar panel receives sufficient light to maintain the battery charge. The Siren should not be operated repeatedly during installation and testing, as this will rapidly drain the battery. It is recommended that the Siren be left for at least a day in order to charge the battery before the system is Armed.

12. Now follow the instructions below to Link the Solar Siren to the Control Panel.

LINKING THE SOLAR SIREN TO THE CONTROL PANEL

When you power up the siren it will automatically be in Service Mode. It cannot be switched out of Service Mode or respond to the control panel until the control panels has been linked to it and the panels ID code learnt into the siren's memory. The siren needs to be placed into Learn mode to complete this.

The full learning process including the actions at the siren is as follows:

1. Place the siren into Learn Mode:

To switch the Siren into Learn mode, press-and-hold the Learn button inside the sirens battery compartment for 5s until the siren enters Learn Mode and produces a single long low volume beep and both Learn and Indicator-LEDs start flashing together slowly (once every 2 seconds).

If there is already a Control Panel linked to the siren then it is not possible to add another. The siren will produce a single long beep and exit Learn Mode.

The siren will remain in Learn Mode for 30s. If a valid signal is not received from a Control Panel within that period it will automatically exit Learn Mode. It will remain in Service mode.

2. Send the ID codes from the panel to the Siren:

Press **7** **ENTER**

Zone 1 LED will be illuminated for 15s while the codes are transmitted.

After 2 seconds the "Siren Stop" signal will be transmitted by the panel to the siren to learn the panel's code.

The siren will produce a single short beep and the Indicator/Learn LEDs will start flashing together rapidly, (once every second).

After 10s the "Siren Stop" signal will automatically be retransmitted by the Control Panel for the siren to confirm the control panels ID code.

The siren will produce single long beep and the Indicator/Learn LEDs will stop flashing and remain ON for 3 seconds after which it will go out to indicate that the Control Panel is now linked to the Siren and its ID code recorded in memory.

3. Now test the Siren as follows:

TESTING THE WIREFREE SOLAR SIREN

With the Control Panel in Test Mode, press **2** to select Siren Test.

The External Siren will be operated for a period of approximately 5 seconds. Zone LED 2 will be illuminated during the test. Wait for the test to end.

4. If this is a new installation, mount the Siren onto the wall as follows.

MOUNTING THE SOLAR SIREN ON TO THE WALL

5. Hold the clear plastic mounting plate supplied in position and mark the positions of the four mounting holes. A spirit level placed on the top edge will help ensure you get the unit level.
6. Undo the fixing screw securing the mounting plate from the bottom edge of the siren and remove the plate.
7. Drill four 6mm holes and fit the wall plugs.
8. Fit the two 30mm fixing screws in the top holes leaving approximately 9mm of the screw protruding.
9. Fit the keyhole slots in the top of the siren over these screws and check that they form a neat fit with minimal movement. If necessary remove the siren and adjust the screws as required.
10. Remove the siren and fit the wall mounting plate in position using the two 25mm fixing screws.
11. Fit the siren to the wall ensuring that the keyhole slots are correctly fitted over the heads of the

two top fixing screws and the lower fixing hole lines up with the wall plate.

- Secure the Siren in place by fitting the lower fixing screw in the wall plate. Do not over-tighten the screw as this could damage the thread.
- Press  to leave Test Mode and return to Standby (Operating Mode).

IMPORTANT: Ensure that the rear tamper switch is closed when you fit the siren cover to the back-plate (i.e. listen for the switch to click). If the switch does not close it will prevent the Siren from operating correctly. If necessary, remove the siren cover again and insert a spacer between the tamper switch plunger and the wall to ensure the switch closes when the Siren is secured in position.

IMPORTANT:
The Siren must now be left in position for at least 24 hours to fully charge the Main Battery before testing or operating the alarm.

SPECTRA LIGHTNING RECEIVER

LINKING THE CONTROL PANEL TO SPECTRA LIGHTING RECEIVER

- Place the Control Panel into Test Mode:

Press , , , , , 
User Access Code

The Arm and Part-Arm LEDs will flash.

- Place the Spectra Receiver into Learn Mode by pressing and holding the 'Learn' button on the module for 3s.
- Send the ID codes from the panel to the Spectra Receiver:



Press , 

Zone 1 LED will flash for 5 seconds while the codes are transmitted.

After 3 seconds a "lights on for 10s" signal will be transmitted by the control panel to the Spectra receiver to learn the panel's code into memory.

The Receiver will automatically exit Learn mode

SPECTRA LIGHTING TEST

- Press , 

The linked Spectra lighting will be activated for 5 seconds.

Zone 5 LED will be illuminated during the test.

- Press  to exit Test Mode.

EXTERNAL CONNECTIONS

(Optional)

The Control Panel incorporates a terminal block for connection of a Hard-wired Siren. The connection terminal block is located inside the Control Panel behind the front cover. To access the terminal block you must first put the system into Test Mode to prevent an alarm occurring.

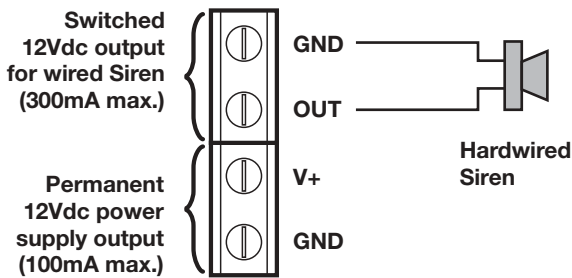
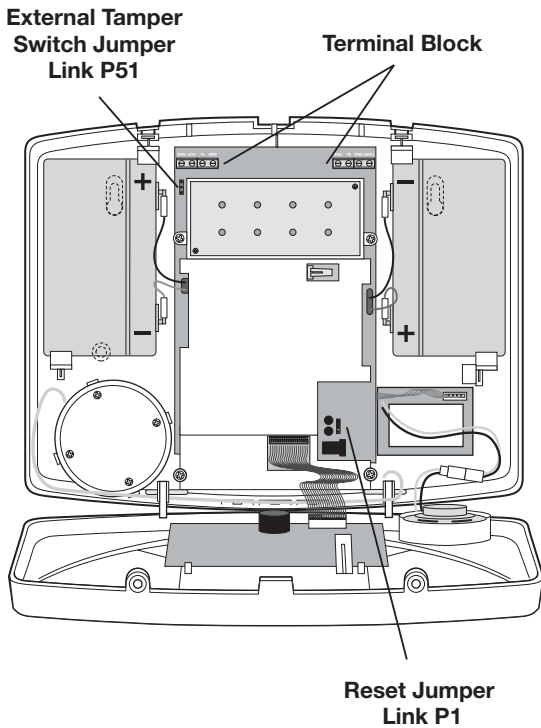

TERMINAL BLOCK DETAIL

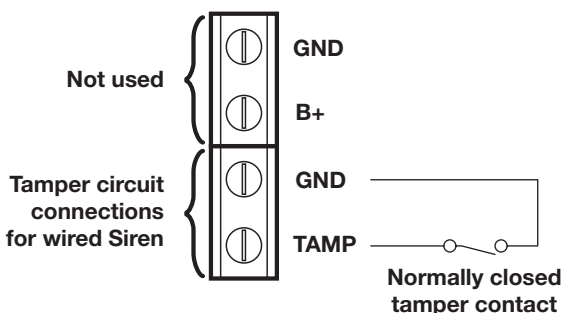

To do this:

Press  , **1** **2** **3** **4** , 
 User Access Code

The Arm and Part-Arm LEDs will flash

Undo the two fixing screws on the top edge of the Control Panel and open the front cover.

Before making any connections, ensure that the Reset Jumper Link P1 is in the 'OFF' position and then remove the DC power jack and disconnect 1 of the back-up batteries.

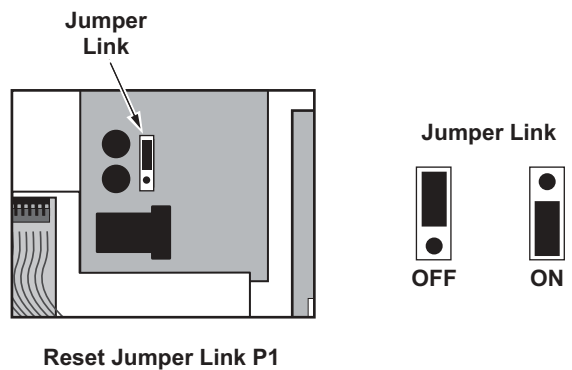

The hardwired zone and tamper switches should be volt free and normally closed, with the contacts opening in order to trigger an alarm.

Note: The External Tamper Switch jumper link P51 should be fitted into the ON position only if the hardwired tamper circuit is used, otherwise it must be in the OFF position.

After making your external connections reconnect the power supply and back-up Battery. Then close the Control Panel cover and tighten the fixing screws on the top edge.

Press  to leave Test Mode and return to Standby.

TESTING THE SYSTEM

The Control Panel has a built in test facility to enable you to test the system at any time. However it is recommended that the system is tested at regular intervals not exceeding 3 months.

With the system in Standby press



The Arm and Part-Arm LEDs will flash

The system is now in Test Mode.

Note: After completing all required test functions press  to leave Test mode and return to Standby.

DETECTOR WALK TEST

Before commencing testing please ensure that there is no movement in any PIR protected area, all doors/windows protected by Magnetic Contact Detectors are closed and that all battery covers are correctly fitted.

An automatic time-out while in walk test will automatically exit the test if no signal is received from any linked device in a 60s period. Each time a valid signal is received the 60s time-out period will be reset.

Note: It may be helpful to have a 2nd person to assist with this test.

Press  

Zone 1 LED will illuminate.

If your system includes Remote Controls:

For each Remote Control:

1. Activate the Panic/PA switch on the side of the Remote Control or

The Control Panel will beep. All Zone, Fire and Tamper LEDs will flash.

2. Press  on the Remote Control:

The Control Panel will beep and the ARM LED will flash.

3. Press  on the Remote Control:

The Control Panel will beep and the PART-ARM LED will flash.

4. Press  on the Remote Control:

The Control Panel will beep and the ARM and PART-ARM LED's will flash.

If your system includes PIR Detectors:

For each Detector:

5. Ensure that the area protected by the PIR has been free from movement for at least 2 minutes and then walk into the area to trigger the detector.

The Control Panel will beep and the appropriate zone LED that the detector is configured on will flash.

Note: To conserve power the PIR will only detect movement if there has been no movement detected within the previous 2 minutes.

6. Remove the battery cover from the detector to operate the anti-tamper switch.

The Control Panel will beep and the TAMPER LED will flash.

7. Replace the detector's battery cover.

If your system includes Magnetic Contact Detectors:

For each Detector:

8. Open the protected door/window to trigger the detector.

The Control Panel will beep and the appropriate zone LED that the detector is configured on will flash.

9. Remove the battery cover from the detector to operate the anti-tamper switch.

The Control Panel will beep and the TAMPER LED will flash.

10. Replace the detector's battery cover.

Press  to exit Detector Test.

WIRE FREE SIREN TEST

Press  

The External Solar Siren will be activated for 5 seconds and then stop.

Zone 2 LED will be illuminated during the test.

INTERNAL SIREN TEST

Press  

The Control Panel internal siren will be activated for 5 seconds and then stop.

Zone 3 LED will be illuminated during the test.

WIRED SIREN TEST

Press  

The hardwired siren only will be activated for 5 seconds and then stop.

Zone 4 LED will illuminate during the test.

SIREN SERVICE MODE

The Solar Siren includes a Service Mode facility which prevents the sirens tamper switch from triggering an alarm while it is removed from the wall for maintenance or to change the batteries. After changing the batteries and refitting in position, the Solar Siren must be put back into Operating Mode, otherwise it will not sound in the event of an alarm (see page 31 for details).

FACTORY SETTINGS

User Access Code:	1 2 3 4
Alarm Duration:	3 minutes
Hardwired Siren:	Equal to Alarm Duration
Zone Operating Mode:	Intruder (all zones)
Part-Arm: Zones 1-4:	Enabled
Zones 5-6:	Disabled
Instant/Delay: Zone 1:	Delay
Zones 2-6:	Instant
Entry/Exit Delay:	30 seconds
Entry/Exit Warning Tone:	On
Zone Lockout:	On
Jamming Detection:	Off

RESET FACTORY SETTINGS

1. Press  ,     , 
User Access Code

This puts the system into Test Mode.

2. Undo the Control Panel cover fixing screws and open the cover.
3. Remove the DC power jack, then remove and disconnect one of the back-up batteries.
4. Set jumper link P1 to the ON position.



5. Reconnect the power supply jack.
6. The Control Panel will now reset itself with all factory settings.
7. The Control Panel will beep and the zone 6 LED will illuminate for 5 seconds and the factory settings will be restored to memory.
8. Reconnect and replace the back-up battery.
9. Reset jumper link P1 into the OFF position.
10. Close the Control Panel cover and refit the fixing screws.
11. Press  to return to Standby.

PROGRAMMING INSTRUCTIONS

With the system in Standby (i.e. with the Power LED ON) press



Note: To get to Standby Mode simply press  repeatedly until only the POWER LED is illuminated.

The Arm and Part-Arm LEDs will illuminate and all Zone, Fire and tamper LEDs will flash together.

The system is now in Program Mode.

Note: After programming all required functions press  to leave Program Mode and return to Standby.

USER ACCESS CODE

This allows the 4 digit User Access code to be changed to your own unique code which only you and other system users should be aware of.

Default setting: 1 2 3 4

To change the setting press  

Zone LEDs 1-4 will illuminate.

Enter the new 4 digit User Access Code. As each digit is entered, an illuminated zone LED will be turned OFF.

Press  to save the new setting and exit to Program Mode, or

Press  to exit without saving.

ALARM DURATION

This allows the alarm duration period (of the Control Panel, Solar Siren and Hardwired Siren) to be set as you require.

Note: Following initiation of a Full Alarm, the Siren will continue to sound until either the system is Disarmed or the Alarm Duration Time expires. However, if the '3 minute alarm time limit' of the Solar Siren is enabled then the Solar Siren will shut down after 3 minutes even if the Control Panel siren is still operating.

Default setting: 3 minutes

Press  

The zone LED corresponding to the current setting will illuminate.

0	no alarm
1	1 minute
2	2 minutes
3	3 minutes
4	5 minutes
5	10 minutes

To change the setting:

Press the button corresponding to the required alarm period, the corresponding zone LED will illuminate as the setting is changed.

Note: When set to 'No alarm' the Siren will sound for approximately 10 seconds if an alarm condition is triggered.

Press  to save the new setting and exit to Program Mode, or

Press  to exit without saving.

ENTRY/EXIT DELAY

This allows the entry/exit delay period applied to 'Delayed' zones to be configured and/or changed. This has no effect on zones configured to 'Instant'.

Default setting: 30 seconds

Press  

The zone LED corresponding to the current setting will illuminate.

1	10 seconds
2	20 seconds
3	30 seconds
4	40 seconds
5	50 seconds
6	60 seconds

To change the setting:

Press the button corresponding to the required delay setting, the corresponding zone LED will illuminate as the setting is changed.

Press  to save the new setting and exit to Program Mode, or

Press  to exit without saving.

INSTANT/DELAY ZONES

This defines which zones will operate in conjunction with the systems entry/exit delay period and which zones will instantly trigger an alarm when activated while the system is armed. Delay zones will not become active (armed) until the exit-delay has expired and when triggered will only initiate an alarm after the entry-delay has expired.

Default setting: zone 1: Delay, zones 2-6: Instant

Press  

The zone LEDs corresponding to the zones currently set to Delay will be illuminated. LEDs for zones set to Instant will be OFF.

LED ON	Delay Zone
LED OFF	Instant Zone

To change the setting:

Press the button corresponding to the zone number to be changed. The zone's status (delay or instant) will switch to the opposite state each time the button is pressed.

Press  to save the new setting and exit to Program Mode, or

Press  to exit without saving.

ENTRY/EXIT WARNING TONE

This allows the warning beeps which are generated during the entry/exit delay to be switched ON or OFF as required.

Default setting: ON (enabled)

Press  

The zone 1 LED will illuminate to indicate the current status of the Entry/Exit warning tone.

LED ON	Tone enabled
LED OFF	Tone disabled

To change the setting:

Press 

The warning tone status will switch to the opposite state each time the button is pressed.

Press  to save the new setting and exit to Program Mode, or

Press  to exit without saving.

PART-ARM

This controls which zones are operational when the Part-Arm feature is activated.

**Default setting: zones 1-4: Enabled
zones 5-6: Disabled**

Press  

The zone LEDs corresponding to the zones currently active during Part-Arm mode will be illuminated. LEDs for zones disabled during Part-Arm will be OFF.

LED ON	Zone enabled in Part-Arm
LED OFF	Zone disabled in Part-Arm

To change the setting:

Press the button corresponding to the zone number to be changed. The zones status will switch to the opposite state (enabled/disabled) each time the button is pressed.

Press  to save the new setting and exit to Program Mode, or

Press  to exit without saving.

ZONE LOCKOUT

This feature if enabled, will only allow a single zone to trigger an alarm up to 3 times before the system is disarmed. However, if this feature is disabled there is no limit on the number of times a zone can trigger an alarm condition.

Default setting: ON (enabled)

Press  

The zone 1 LED will illuminate to indicate the current Zone Lockout status.

LED ON Zone Lockout enabled
LED OFF Zone Lockout disabled

To change the setting:

Press **1**

The Zone Lockout status will switch to the opposite state (enabled/disabled) each time the button is pressed.

Press **ENTER** to save the new setting and exit to Program Mode, or

Press **ESC** to exit without saving.

JAMMING DETECTION

This controls the systems anti-jamming detection facility. It is recommended that the jamming detection is not activated for at least the first 30 days to allow time for you to become familiar with the operation of your systems first.

Default setting: OFF (disabled)

Press **7** 

The zone 1 LED will illuminate to indicate the current Jamming Detector status.

LED ON Jamming Detection enabled
LED OFF Jamming Detection disabled

To change the setting:

Press **1**

The jamming detection status will switch to the opposite state (enabled/disabled) each time the button is pressed.

Press **ENTER** to save the new setting and exit to Program Mode, or

Press **ESC** to exit without saving.

Note: The jamming detection program setting will only control the jamming detection feature in the Control Panel. The jamming detection function incorporated in the Siren operates independently.

SPECTRA LIGHTING STATUS

Press **8** 

The current status of the Spectra Lighting control features is indicated on the zone 1 LED as follow:

Spectra Lighting Control
Disabled (OFF) zone 1 LED OFF
Spectra Lighting Control
Disabled (ON) zone 1 LED ON

To change the setting:

Press **1**

The On/Off status will switch to the opposite state on each button press.

Press **ENTER** to save the new setting and exit to Program Mode, or

Press **ESC** to exit without saving.

SPECTRA LIGHTING TIME-ON PERIOD

Press **9** 

The current setting for the Spectra lighting time-on period will be displayed on the zone LEDs as follow:

Time on period	Illuminated LEDs	Selection Button
0	all off	press 0
1 minute	zone 1	press 1
2 minutes	zone 2	press 2
3 minutes	zone 3	press 3
5 minutes	zone 4	press 4
10 minutes	zone 5	press 5
20 minutes	zone 6	press 6

To change the setting:

Press the button corresponding to the required alarm period, the corresponding zone LED will illuminate as the setting is changed.

Press **ENTER** to save the new setting and exit, or

Press **ESC** to exit without saving.

ZONE OPERATING MODE

Each alarm zone provides only a standard intruder monitoring with normal Arm and Part-Arm functions.

OPERATING INSTRUCTIONS

When leaving the premises, the system must be Armed. However, before doing so, check that all windows are closed and locked, all protected doors are closed and PIR Detectors are not obstructed. Ensure that pets are restricted to areas not protected by PIR Detectors.

The system has 2 armed modes, ARM and PART-ARM. The Part-Arm facility allows for selected zones to be left disarmed whilst the remainder of the system is Armed.

When the system is Armed (in either mode) the Zone LEDs for all active zones will illuminate for a few seconds. Also the appropriate Arming Mode LED will flash. All active zones set as INSTANT will immediately be Armed and will be able to trigger an alarm. If enabled, the system exit-delay will start and the Control Panel will start beeping, (the beep rate increasing in steps as the delay period expires). When the exit-delay expires all active zones set to 'Delay' will be Armed and able to trigger an alarm. By this time the user must have left the property and closed the final protected door.

If while the system is armed a detector on an INSTANT zone is triggered then this will immediately trigger an Alarm with both the Control Panel and Siren sounding. However, if a detector on a DELAY zone is triggered, the entry-delay (if enabled) will start and the Control Panel will start beeping with the beep rate increasing in steps as the delay expires. If the system has not been Disarmed when the entry-delay period expires, the Alarm will sound. When an Alarm occurs the LED corresponding to the zone that triggered the alarm will flash.

At the end of the programmed alarm duration the Siren and Control Panel alarms will stop and the system will automatically re-arm itself, (subject to the conditions of the Zone Lockout feature).

Notes:

- To conserve power and maximise battery life the PIR detector will only detect movement if there has been no movement detected within the previous 2 minutes.
- If the Solar Siren is fitted and the 3 minute limit is enabled then the siren will stop when the

programmed alarm duration expires or after 3 minutes, whichever occurs first.

ARMING THE SYSTEM

The system can be set in FULL ARM mode using either the Remote Control or the Control Panel as follows:

a. Press  on the Remote Control, or

b. Press , , , , , ,
User Access Code

on the Control Panel.

PART-ARMING THE SYSTEM

The system can be set in PART-ARM mode using either the Remote Control or the Control Panel as follows:

a. Press  on the Remote Control, or

b. Press , , , , , ,
User Access Code

on the Control Panel.

DISARMING THE SYSTEM

The system can be Disarmed using either the Remote Control or the Control Panel as follows:

a. Press  on the Remote Control, or

b. Press , , , , , ,
User Access Code

on the Control Panel.

If the system has been triggered, the appropriate LED will be illuminated to indicate which zone(s) have triggered the alarm and the panel will beep every 10 seconds.

To stop the LED flashing and panel beeping press .

Note: If the system is Disarmed with the Remote Control the Siren will beep twice, (unless the warning beeps have been disabled on the Siren).

PERSONAL ATTACK (PA) ALARM

An Alarm can be immediately triggered at any time (whether the system is Armed or Disarmed) in the event of threat or danger by activating a Personal Attack (PA) switch on either the Remote Control or the Control Panel as follows:

- a. Slide the Personal Attack switch on the Remote Control upwards, or
- b. Press and hold the  button for approximately 3 seconds on the Control Panel.

The alarm will continue either for the alarm duration after which the system will automatically reset or until the system is disarmed. All zone, Fire and Tamper LEDs will flash together continuously.

After disarming the system press  to clear the indication.

DEVICE TAMPER

If the battery cover of any device (except a Remote Control) is removed or if the Siren or Control Panel are removed from the wall then an alarm will immediately occur (unless the system is in Test or Program Modes), even if the system is Disarmed.

The Tamper LED on the Control Panel will illuminate to indicate the Tamper Alarm has been activated.

After disarming the system press  to clear the indication.

Note: The Tamper protection facility on the Siren operates independently of the Control Panel. If the Tamper on the Siren is activated this will not be indicated at the Control Panel.

FIRE ZONE(s)

The dedicated Fire zone operates on a 24 hour basis. (i.e. Receipt of an alarm signal from a smoke/fire alarm will immediately trigger an alarm irrespective of systems armed/disarmed status unless the system is in program or Test modes).

The Fire LED will flash continuously.

After disarming the system press  to clear the indication.

Notes:

1. The fire alarm sound will be different to that generated from an intruder alarm.
2. The fire alarm will sound at the control panel only.
3. The fire alarm at the control panel will be started and stopped under command from the smoke detector. It will not be under control of the programmed alarm duration. I.e. if the smoke alarm stops sounding then the alarm at the control panel will also stop.
4. The alarm at the control panel may also be stopped by disarming the system in the normal way.

SIREN SERVICE MODE

In order to remove the Solar Siren from the wall to change the batteries, it is necessary to place the Siren into Service mode to prevent the Tamper switch on the Siren operating and triggering an alarm. When you have completed any alterations to the system you must remember to switch the siren back into Operating Mode.

The Siren can be switched into Service mode using either the Remote Control or Control Panel as follows:

Remote Control:



Press and hold the  button for approximately 5 seconds.

After 5 seconds, the siren will produce two short beeps followed 1 second later by a single long beep. The Siren LEDs will flash together in conjunction with the beeps.

Control Panel:

With the system in Standby Mode with the Power LED ON:

Press , , , , , 
User Access Code

Press ,  to switch the Siren into Service Mode.

Zone 6 LED will be illuminated for 3 seconds while the "Siren Service Mode ON" signal is transmitted.

Service Mode: The siren will produce two short beeps followed 1 second later by a single long beep. The Siren LEDs will flash together in conjunction with the beeps.

Press  to return to Standby.

SIREN OPERATING MODE

The Siren can be switched back into Operating Mode using either the Remote Control or Control Panel as follows:



Remote Control:

Press and hold the  button for approximately 5 seconds.

After approximately 5 seconds The siren will produce a single long beep followed 1 second later by two short beeps. The Siren LEDs will flash together in conjunction with the beeps. The button must be released during or immediately after the long beep, otherwise the system will switch into an Armed state.

Control Panel:

With the system in Standby Mode with the Power LED ON:

Press   to switch the Siren out of Service Mode and back into Operating Mode.

The Fire LED will be illuminated for 3 seconds while “Siren Service Mode OFF” signal is being transmitted.

Operating Mode: The siren will produce a single long beep followed 1 second later by two short beeps. The Siren LEDs will flash together in conjunction with the beeps to indicate that it has switched out of Service Mode.

Press  to return to Standby.

BATTERY MONITORING

Low Battery Condition

If the Siren is at low battery condition, pressing the Disarm button on the Remote Control or Keypad will cause the Siren to generate 3 short beeps.

All system devices continuously monitor their battery condition. When a low battery indicator is

activated the device will continue to operate normally for up to 2 weeks (depending upon system use). However, the battery for that device should be replaced as soon as possible.

In addition, if any PIR, Magnetic Contact Detector or Smoke Detector has a low battery status it will be indicated on the ‘LOW BAT’ LED on the Control Panel as follows:

LED Flashing	Magnetic Contact Detector
LED Flashing	PIR Detector
LED Flashing	Smoke Detector
LED Flashing	Remote Control/Keypad

Note: Before removing the battery cover on any device to replace the battery, ensure that the system is put into Test Mode to avoid triggering an Alarm.

The low battery indication built into each system device is as follows:

Control Panel:

During a period of mains supply interruption the Control Panel will be powered by the rechargeable backup batteries.

Under normal battery conditions the Power LED on the panel will flash at 1 second intervals. However, under low battery conditions the Power LED will flash at 3 second intervals.

Remote Control:

When the Remote Control is operated under low-battery conditions the transmit LED will continue to flash after the button has been released.

Under normal battery conditions for the Remote Control, the LED will extinguish within 2 seconds of the button being released.

PIR Movement Detector:

Under low battery conditions the LED behind the detector lens will flash when movement is detected to indicate that the battery needs to be replaced.

Under normal battery conditions the LED does not illuminate unless the PIR Detector is in Walk Test mode.

Magnetic Contact Detector:

Under low battery conditions, when the Detector is activated, the LED will be illuminated for approximately 1 second as the door/window is opened.

Under normal battery conditions the LED will not illuminate as the Detector is operated, (unless the Detector is in Test Mode with the battery cover removed).

The indicator on the Control Panel can be cancelled by pressing . The LED will start flashing on receipt of the next low battery signal.

SPECTRA PLUS LIGHTENING

If the Control Panel is linked to a Spectra plus Lighting Receiver and the Spectra Lighting Control is enabled then any alarm condition (except Fire alarms) will cause the linked lighting to be switched on for the set light-on duration.

Note: Spectra lighting signal to be sent each time a Tamper or PA switch is triggered and each time a detector on an enabled zone is triggered when the panel is armed.

Spectra Manual - On/Auto switching:

Press  to switch the linked Spectra lighting ON.

Press  to switch the linked Spectra lighting OFF and back to automatic operation.

MAINTENANCE

Your Alarm System requires very little maintenance. However, a few simple tasks will ensure its continued reliability and operation.

IMPORTANT: If, for any reason you have to completely power-down the system (e.g. to move the system to new premises), first put the system into Service Mode before removing the Siren cover and disconnecting the main rechargeable and initial power-up batteries. Ensure that the solar panel is covered with a lightproof material to prevent it being energised, otherwise the solar panel may still power the siren.

SOLAR SIREN

1. It is recommended that the solar panel on the top of the siren housing should be cleaned at least twice a year, preferably in the Spring and Autumn, using a soft damp cloth. Do not use abrasive, solvent based or aerosol cleaners. Do not attempt to clean inside the unit or allow water to enter the unit.

This will ensure that the solar panel does not become affected by the build up of excessive dirt and receives all the available light.

2. The Siren should not be left for long periods with the batteries connected, unless the unit is able to receive sufficient light to maintain the battery charge. Failure to maintain charge to the unit will result in the rechargeable battery running unacceptably low. Should this occur, the unit must be recharged from a 7.5Vdc/100mA supply (e.g. from a mains adaptor power supply). When re-powering the Siren, fit a new 9V PP3 leak-proof Alkaline power-up battery to ensure that the Siren receives sufficient power until the solar panel can recharge the main battery.
3. The main rechargeable battery has a typical life of 3 - 4 years and needs no maintenance during this period, provided the battery is kept charged. The battery will be damaged if it is stored in a discharged state for long periods.

IMPORTANT: Before removing the Siren from the wall ensure that the Siren is first switched into Service Mode to prevent the Tamper switchoperating and triggering an alarm, (see page 19). The Siren must be switched back into Operating Mode, otherwise the system cannot be Armed.

CONTROL PANEL

The rechargeable batteries have a typical life in excess of 3 to 4 years and need no maintenance during this period, provided they are kept charged. The batteries will be damaged if they are stored in a discharged state for long periods.

DETECTORS, REMOTE CONTROL AND KEYPAD

The Detectors, Remote Control and Keypad require very little maintenance. The batteries should be replaced once a year or when a low battery status is indicated.

BATTERIES

Note: Before removing the battery cover on any device to replace the battery ensure that the Siren is switched into Service Mode to avoid triggering an alarm. The Siren must be switched back into Operating Mode after fitting new batteries otherwise the system will not operate.

The specifications for replacement batteries are as follows:

Remote Control: 1 x 3V CR2032 Lithium Cell (or equivalent)
Magnetic Contact Detector: 2 x 3V CR2032 Lithium Cells (or equivalent)
PIR Movement Detector: 1 x 9V PP3 Alkaline Battery
Keypad: 1 x 9V PP3 Alkaline Battery

Note: Rechargeable batteries should NOT be fitted.

DISPOSAL

At the end of their useful life the packaging, product and batteries should be disposed of via a suitable Recycling Centre.

Do not dispose of with your normal household waste. **DO NOT BURN.**



The Rechargeable Batteries contain Sulphuric Acid – **DO NOT ATTEMPT TO OPEN THE CASING.**

TROUBLE SHOOTING

Symptom / Recommendation

Control Unit not working – Power LED OFF or flashing.

1. Mains power failure - check if other electrical circuits are operable.
2. Check that mains adaptor is plugged in and socket is switched ON.
3. Check that DC jack plug from mains adaptor is connected in Control Panel.
4. Check fuse/MCB in Consumer Unit on the circuit serving the Control Panel.

Note: Before replacing any fuses or resetting the MCB, the cause of the failure should be investigated and rectified.

Control Unit “Low Battery” LED flashing.

1. Check all PIR Detectors for low battery indication, (i.e. LED behind detection lens flashes when movement detected).
Renew batteries as required.

Control Unit “Low Battery” LED illuminated.

1. Check all Magnetic Contact Detectors for low battery indication, (i.e. LED on Detector illuminates for 1 second when detector triggered). Renew batteries as required.

Control Unit not accepting User Access Code.

1. Pause between key depressions too long. Do not pause for more than 3 seconds between pressing keys.
2. Incorrect code entered. Press ESC before re-entering correct code.
3. Reset to factory defaults and reprogram system.

Siren not responding to detector.

1. Detector battery low - Replace battery.
2. Siren in Service Mode – switch back to Operating Mode using Remote Control or Control Panel.
3. Ensure Siren and Detector's ID Code' is learnt by the Control Panel.
4. Ensure detector is within effective radio range of Siren and equipment is not mounted close to metal objects.

Detection Zone triggered (LED flashing) but no alarm is sounding.

1. Entry/Exit delay still running and not yet expired.
2. Alarm duration period has already expired and system has reset.
3. Alarm duration programmed to “no alarm”.

Siren and Indicator LEDs operating but no alarm at Control Panel.

1. Siren's Tamper switch activated. Check security of Siren fixing to wall and adjustment of anti-tamper switch to ensure switch is fully depressed.
2. Siren's Jamming Detection circuit operated, (jamming detection at Control Panel disabled).

Siren not responding to Control Panel.

1. Ensure 'ID Code' is learnt by the Control Panel.
2. Ensure main Siren configuration switch is set to SIREN.
3. Incorrect User Access code being entered at Control Panel.
4. Ensure Siren is within effective radio range of Control Panel and equipment is not mounted close to metal objects.

5. Siren rechargeable battery discharged
 - a. Clean Solar Panel.
 - b. Check age of rechargeable battery – replace if at end of useful life.
 - c. Fit new initial power-up battery and re-power up Siren.

Full Alarm sounds when system has not been triggered by an intruder or is disarmed.

1. Tamper switch activation
 - a. Check all detector battery covers to ensure correctly fitted.
 - b. Check Control Panel and Siren are securely mounted to the wall and Tamper switch is closed.
2. Personal Attack Alarm operated from a Remote Control or Control Panel.
3. Jamming Detection circuit operated.

LED on Remote Control not illuminating, or is dim when unit is operated.

1. Ensure battery is fitted with correct polarity.
2. Ensure battery holder connections are making good contact with the battery.
3. Battery flat - replace battery.

PIR Detector false alarming.

1. Ensure that the detector is not pointing at a source of heat or a moving object.
2. Ensure that the detector is not mounted above a radiator or heater.
3. Ensure that the detector is not facing a window or in direct sunlight.
4. Ensure that the detector is not in a draughty area.
5. Sensitivity set too HIGH – reset to LOW sensitivity. (i.e. SW3 to down position).

PIR Detector not detecting a person's movement.

1. Ensure the battery clip is securely connected.
2. Ensure 'ID Code' is learnt by the Control Panel into a particular zone.
3. Sensitivity set too LOW – reset to HIGH sensitivity. (i.e. SW3 to up position).
4. Ensure that detector is mounted the correct way up, (i.e. with detection window at the bottom).
5. Ensure that the detector is mounted at the correct height, (i.e. 2-2.5 metres).
6. Allow up to 3 minutes for detector to stabilize and become fully operational. Leave the area for this period.
7. Ensure detector is within effective radio range of the Control Panel and is not mounted close to metal objects which may interfere with Radio transmission.

PIR Detector LED flashes on detection of movement, (device in normal operation mode).

1. PIR still in walk test mode for fixed 5 minutes if the pcb button was activated.
2. Low battery - replace battery.

Magnetic Contact Detector not working.

1. Ensure that Magnet is correctly positioned in relation to Detector and that the gap between Magnet and Detector is less than 10mm.
2. Ensure batteries are fitted with correct polarity (correct way around).
3. Ensure battery holder connections are making good contact with the batteries and Circuit Board.
4. Ensure 'ID Code' is learnt by the Control Panel into a particular zone.
5. If there is no additional wired Magnetic Contact connected, ensure jumper link is fitted.

6. If an additional wired Magnetic Contact is connected:
 - a. Check that both contacts are closed.
 - b. Check that additional contact is correctly wired and switch SW3 set to middle or bottom position.

Note: If an additional contact is used then the doors/windows protected by both the main wirefree detector and the additional wired detector must be closed when either is opened. If one of the doors/windows is already open then the opening of the other door/window will not be detected.

7. Ensure detector is within effective radio range of Control Panel and is not mounted close to metal objects which may interfere with Radio transmission.

Magnetic Contact Detector false alarming.

1. Ensure that magnet is correctly positioned in relation to detector.
2. Ensure that gap between magnet and detector is less than 10mm.
3. Tamper switch below battery cover is not depressed - check battery cover is fitted correctly and that fixing lugs are not broken.

LED on Magnetic Contact Detector illuminating when door or window is opened.

1. Low battery - replace batteries.

HELPLINE

If you have any problems with your alarm, please call the Helpline on:

0870 850 3015

(Lines open 9.00am to 5.00pm, Monday to Friday.
Calls charged at service providers national rate).

EXTENDING YOUR ALARM SYSTEM

The following additional accessories are available to enhance your system and provide further protection and a higher level of security where required.

ACCESSORIES

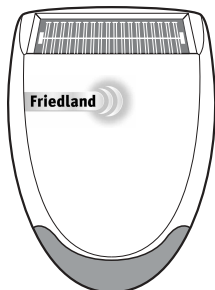

HS0
DUMMY SIREN

1 x Dummy Solar Siren

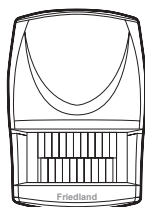

HS2
PIR MOVEMENT DETECTOR

1 x PIR Movement Detector



HS3
REMOTE CONTROL

1 x Remote Control

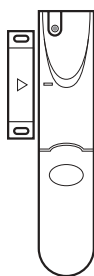

HS4
MAGNETIC CONTACT DETECTOR

1 x Magnetic Contact Detector

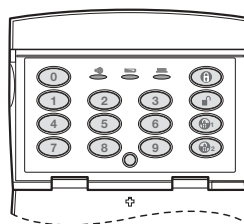

HS5
REMOTE KEYPAD

1 x Remote Keypad

GUARANTEE

Novar ED&S undertakes to replace or repair at its discretion goods (excluding non rechargeable batteries) should they become defective within 1 year solely as a result of faulty materials and workmanship. Understandably if the product has not been installed, operated or maintained in accordance with the instructions, has not been used appropriately or if any attempt has been made to rectify, dismantle or alter the product in any way the guarantee will be invalidated.

The guarantee states Novar ED&S entire liability. It does not extend to cover consequential loss or damage or installation costs arising from the defective product. This guarantee does not in any way affect the statutory or other rights of a consumer and applies to products installed within the UK and Eire only.

If an item develops a fault, the product must be returned to the point of sale with:

1. Proof of purchase.
2. A full description of the fault.
3. All relevant batteries (disconnected).

Friedland is a trademark of Novar ED&S.

COMPONENT SPECIFICATION

External Solar Siren

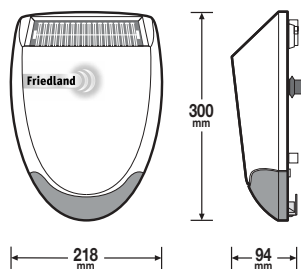

- RF operating frequency: 868MHz
- Sealed lead acid battery 6V/1.2Ahr
- Solar Panel 7.5V - Charge Rate typically 60mA
- Operation time in complete darkness – up to 25 days
- 95dB Piezo Siren
- 3 minutes alarm duration limiter (optional)
- Siren Disable (selectable)
- Anti-tamper protection
- Jamming Detection
- Audible confirmation

Remote Control

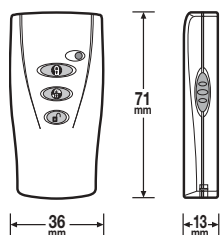

- RF operating frequency: 868MHz
- Range: 80 metre max.
- Personal Attack (PA) switch
- Operates all ARM, PART-ARM, and DISARM functions
- Transmission indicator
- Battery life >1 year
- Low battery indicator
- RF Jamming Detection
- Low Battery Indicator

Control Panel

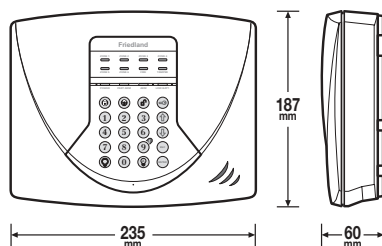

- RF operating frequency: 868MHz
- Range: 125 metre max.
- Battery back-up
- Detector Low-Battery Status Indication
- 6 Zones
- Part-Arm Facility
- Instant or Delayed Alarm Zones
- Entry/Exit Delay Alarm Modes
- Entry/Exit Delay Warning (selectable)
- 90dB High Power Piezo Siren
- Connections for Hardwired Siren
- Programmable 4 digit User Access Code
- Programmable Alarm Duration
- Programmable Entry/Exit Delay
- Auto Reset
- Zone lockout
- Siren Disable (selectable)
- Dual front & rear anti-tamper protection
- Personal Attack (PA) Alarm

PIR Infra-Red Movement Detector

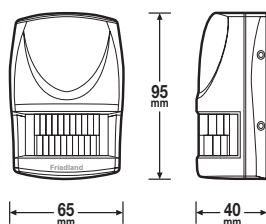

- RF operating frequency: 868MHz
- Range: 150 metre max.
- Detection range: 12 metres at 110°
- Walk test facility
- LOW/HIGH Detection Sensitivity
- Anti-tamper protected
- Corner or surface mount
- Battery Life >1 year
- Low Battery Indicator

Keypad (Optional)

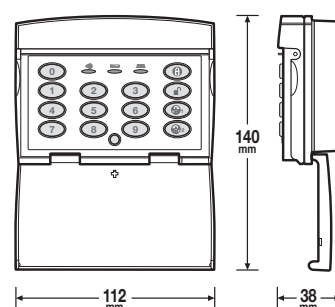

- RF operating frequency: 868MHz
- Range: 125 metre max.
- Changeable 4 digit User Access code
- Anti-tamper protected
- Personal Attack (PA) facility
- Battery Life >1 year
- Low Battery Indicator

Magnetic Contact Detector(s)

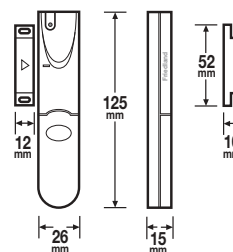

- RF operating frequency: 868MHz
- Range: 150 metre max.
- Test Mode
- Anti-tamper protection
- Facility to connect additional wired Magnetic Contact
- Battery Life >1 year
- Low Battery Indicator

RESEARCH & DEVELOPMENT

Our R & D Department is constantly developing new products. We practice a policy of continued improvement and reserve the right to change specifications without prior notice.

Novar Electrical Devices and Systems are Quality Assurance Registered to BS EN ISO9001 2000, by Asta.

HELPLINE

If you have any problems with your alarm, please call the Helpline on:

0870 850 3015

(Lines open 9.00am to 5.00pm, Monday to Friday. Calls charged at service providers national rate).



Friedland, Novar Electrical Devices and Systems Limited.

The Arnold Centre, Paycocke Road, Basildon, Essex SS14 3EA. UK.

51063PL Ed.1