

Accenta/Optima

User Guide

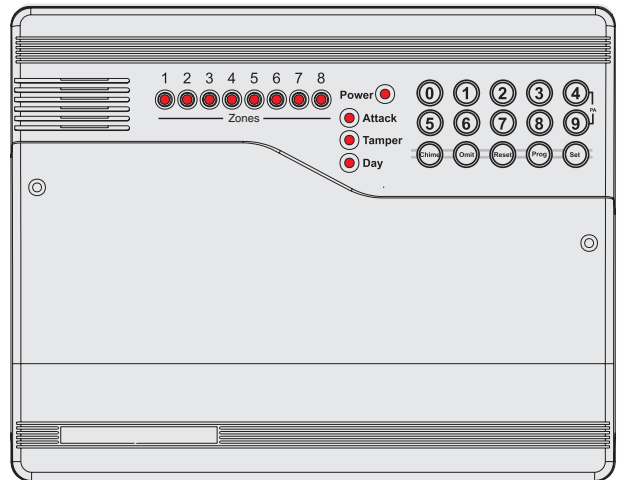
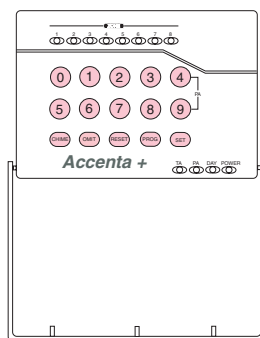
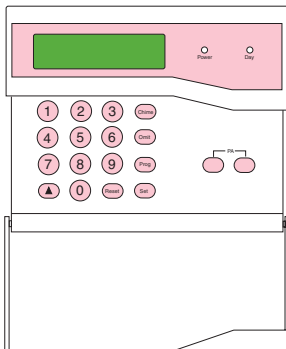

Servicing Organisation (Installer) name: _____

Telephone Number: _____

Date of Installation: _____

Account Number: _____

Contents

Introduction..... 1

Codes 1

Alarm System Operation 1

Personal Attack 1

Fire Zones 1

Power Indicator 1

Signalling Device 1

How to Set the System 2

How to Unset the System 3

How to Part Set the System 4

How to Silence an Alarm and Reset the System 5

How to Omit Zones 6

How to Quick Set the System 7

Single Key Setting 7

How to Set Up Chime Mode 8

Changing Codes Using User 1 9

Changing Codes Using User 2 10

How to Delete User Code 2 11

 To delete user code 2 using user code 1 11

 To delete user code 2 using user code 2 12

Duress Code 13

How to View the Event Log 14

How to Test Your Alarm system 15

 How to Test the Bell, Strobe and Internal Sounder 15

How to do a Walk Test 17

How to Set up the Time and Date 18

Introduction

This User Guide tells you how to operate your intruder alarm system. To simplify this User Guide we have assumed that the alarm system has been installed by a professional intruder alarm system installer (the installer), and that the system is operated in a “typical” way. Aspects of your system that are not “typical” will be described by your installer.

NOTE: If you have any questions about your intruder alarm system, then consult your installer, see contact details at the front of this User Guide.

Codes

To operate the alarm system you will need to use a code. A code is 4 digits long, and can be any number from 0000 to 9999. By default user code 1 is [0][1][2][3] but you should change this as soon as possible.

Alarm System Operation

This booklet describes three versions of the alarm system. The **Optima** version has the keypad and indicators on the main control panel. The **Accenta** version has the keypad and indicators on a small remote LCD or LED keypad. You operate the alarm system by pressing buttons on the keypad and viewing the indicators. Both alarm systems work the same way. Both **Accenta** and **Optima** systems can be fitted with an optional remote keypad.

Personal Attack

If the installer has programmed personal attack on the keypads and if you are under threat, or are being attacked, you can activate the alarm by pressing the **4** and **9** keys at the same time on any LED keypad. You can also press the two keys marked **PA** on the remote LCD keypad. The alarm system will produce a loud alarm sound, and the external siren will be turned on.

Fire Zones

Zones 7 and 8 on your alarm system may have a Fire or Smoke detector connected to it. In the event of a fire the alarm system will produce a distinctive two-tone fire alarm sound, and the outside siren will pulse 2 seconds on, 2 seconds off. You should leave the premises immediately, and only re-enter when it is safe to do so. The alarm can be silenced by entering your code.

Power Indicator

The **Power** indicator on the control panel or keypad will light whenever the mains power supply is present. If mains power fails then the **Power** indicator will go out, but the system will run from its backup battery for several hours. If the **Power** indicator goes out when mains power is present then a fault may have developed on your system and you should contact your installer.

Signalling Device

Your alarm system may have been fitted with a signalling device. This device uses the telephone line to send an alarm message to an Alarm Receiving Centre in the event of an alarm. The operator at the ARC may request the police to attend your premises.

How to Set the System

When you leave your premises you will need to set (or turn on) the intruder alarm system.

Before setting the system you should ensure that the premises have been completely vacated and that all doors and windows are closed. Ensure that pets do not have access to the protected areas as they can cause a false alarm.

NOTE: The Accenta Remote LED keypad is not shown. It will have the same indications as the Optima compact panel with built-in keypad.

NOTE: There will be no exit beeps if **Silent Timed** exit mode was programmed.

LCD Keypad: the **Day** LED should be on. The screen shows the day mode:

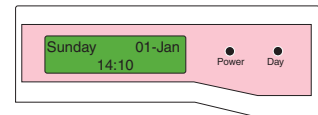

LED Keypad: the **Day** LED should be on.

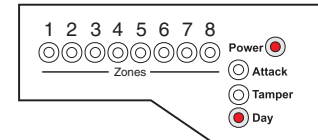

NOTE: You should wait until you hear that the exit beep has stopped before assuming that the system has set.

LCD Keypad:

- Enter your 4-digit code (**0123** default) and check that the system is clear.
- The exit tone begins to sound and the display shows program 1 in process of setting.
- Leave the premises by the agreed exit route.
- The exit tone becomes rapid during the last 10 seconds and then stops when the system sets. The **Day** LED goes off and **SYSTEM SET** appears on the screen
- After 30 seconds the set mode display appears.

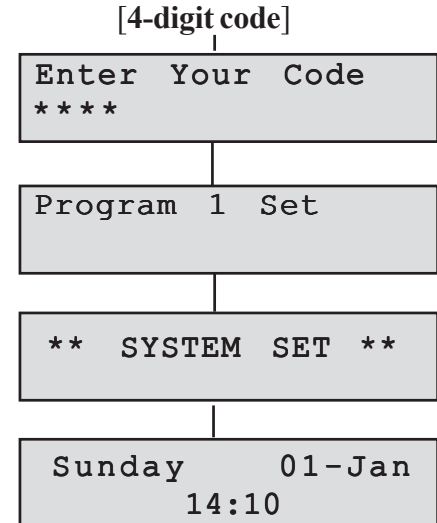

LED Keypad:

- The system is unset. The **Power** and **Day** LED's are on.
- Enter your 4-digit code (**0123** default) and check that the system is clear (no zone LED's on).
- The exit tone begins to sound to indicate that the system is in the process of setting.
- Leave the premises by the agreed exit route.
- The exit tone becomes rapid during the last 10 seconds and then stops when the system sets. The **Day** LED goes off.

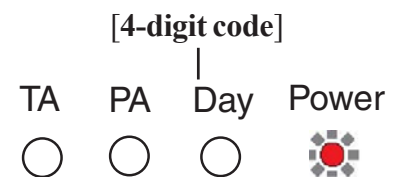

How to Unset the System

When you enter your premises you will need to unset (turn off) the system.

LCD Keypad:

- Enter the premises by the agreed entry route. The system produces an entry tone. The **Power** LED is on and the **Day** LED is off indicating that the system is set.
- Enter your 4-digit code (**0123** default).
- The system unsets with a double beep. The **Day** LED comes on indicating that the system is unset.
- After 30 seconds the **Day** mode display appears.

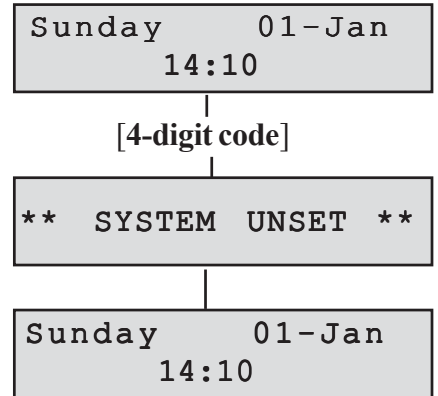

LED Keypad:

- Enter the premises by the agreed entry route. The system produces an entry tone. The **Power** LED is on and the **Day** LED is off indicating that the system is set.
- Enter your 4-digit code (**0123** default).
- The system unsets with a double beep. The **Day** LED comes on indicating that the system is unset.

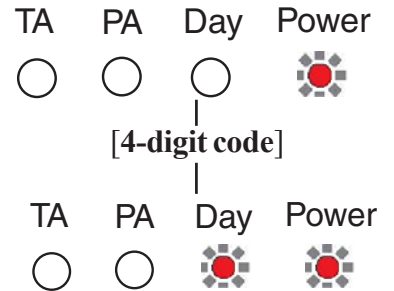

If any Zone, TA (Tamper) or PA (Attack) LED's come on then an alarm has occurred, and an intrusion may have taken place. Seek assistance before investigating further as intruders may still be on the premises. Then reset the system.

When you enter your premises you will have a short period of time, usually 30 seconds, to enter your code. If you fail to do this the system will go into alarm. Enter your code to stop the alarm.

How to Part Set the System

If your installer has programmed your system for **part set** operation you will be able to set some zones of the system while others remain unset. Part set operation is often used at night time, and it will permit you to freely walk around the bedrooms while the living area and outside doors are protected. Your system may have 2 part-set programs called Program 2 and Program 3.

Before part-setting the system you should ensure that all doors and windows are closed. Ensure that pets do not have access to the protected areas. Your installer may have instructed you to use a different keypad to the one normally used to set the system.

LCD Keypad:

- The **Day** LED should be on. The screen shows the **Day** mode:
- Enter your code [0][1][2][3]. The exit beep starts.
- Press the [PROG] key. The exit tone stops.
- Select part-set program [2] or [3]. The system will set after a short time. The **Day** LED goes out.

NOTE: There will be no exit beeps if **Silent Timed** exit mode was programmed.

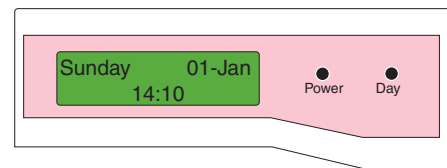

[4-digit code]

Program 1 Set

[PROG]

Set System
Select 1 2 or 3

[2 or 3]

** SYSTEM SET **

Sunday 01-Jan
14:10

LED Keypad:

The **Day** LED should be on.

- Enter your code [0][1][2][3]. The exit beep starts.
- Press the [PROG] key. The exit tone stops and the zone LED's 1 to 3 come on.
- Select part-set program [2] or [3]. The system will set after a short time. The **Day** LED goes out.

NOTE: There will be no exit beeps if **Silent Timed** exit mode was programmed.

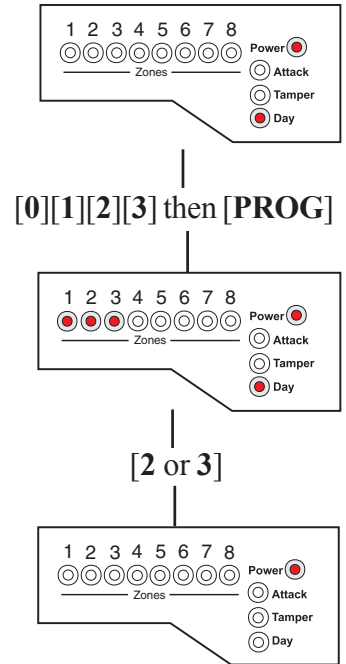

How to Silence an Alarm and Reset the System

If your system goes into alarm then be aware that intruders may be in the premises. Seek assistance before investigating the cause of the alarm.

LCD Keypad:

- Enter your code [0][1][2][3]. The alarm will stop.
- The screen alternates showing what caused the alarm and prompting for user reset

When two or more alarms have occurred, the first alarm will have an **F** below the zone number, **Tamper** or **PA**. Subsequent alarms will have a **1** indicating where the alarm has taken place.

- Press [RESET]. The system resets and goes into day mode if there are no open Tamper, PA or Fire zones to cause a fault lockout.

The system can be reset by the user only if the installer has programmed it to do so. If the message **Engineer Restore Required** appears on screen then the user will have to contact the installer.

- After 30 seconds the set mode display appears.

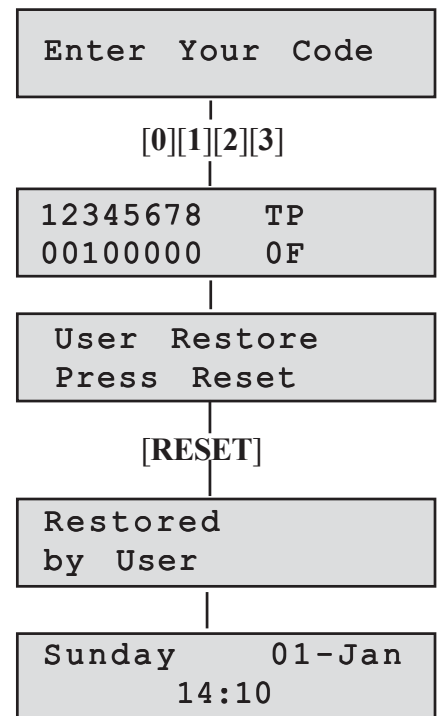

LED Keypad:

- Enter your code [0][1][2][3].

The alarm will stop, and the **Zone**, **Tamper (TA)** or **Attack (PA)** LED's will come on to show the cause of the alarm.

NOTE: When 2 or more LED's are on, the flashing indicator shows the first alarm, and the steady indicators show the second and subsequent alarms.

- Press [RESET].
- If the **Zone**, **Tamper (TA)** or **Attack (PA)** LED's go out and the **Day** LED comes on then the system has been reset.

If any of the LED's continue to flash then the system has been programmed to be reset by the installer. In this case you must call the installer to reset the system.

If all LED's light steady (not flashing), and the keypad stops working, then the system has entered a fault-lockout. You must call the installer to rectify this fault.

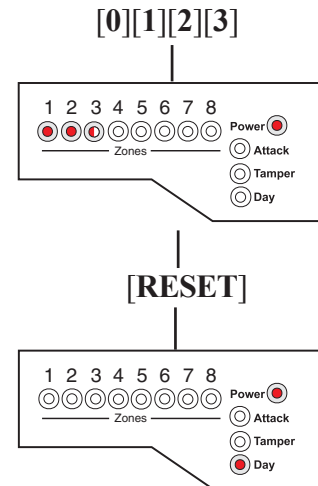

How to Omit Zones

If you cannot set the alarm system because a detector is faulty and in constant alarm you may need to omit its zone from the alarm system. A zone which has been omitted cannot cause an alarm. Omitted zones will be restored after the system is unset.

Before a zone can be omitted it has to be enabled by the installer as a **Used Zone** and as an **Omit Allow** zone.

LCD Keypad:

- Enter your [4-digit code] to start the exit procedure (for more information see **How to Set the System**).
- Press [OMIT] and the exit beep tone will stop, and the first used zone that can be omitted will appear on the display.
- Press the zone [number] or [up arrow] to be omitted. The display will now show the zone as omitted. If a flat reject tone is heard, then the zone cannot be omitted.
- Press [SET] or allow the system to continue to set.

NOTE: Zn = Zone number

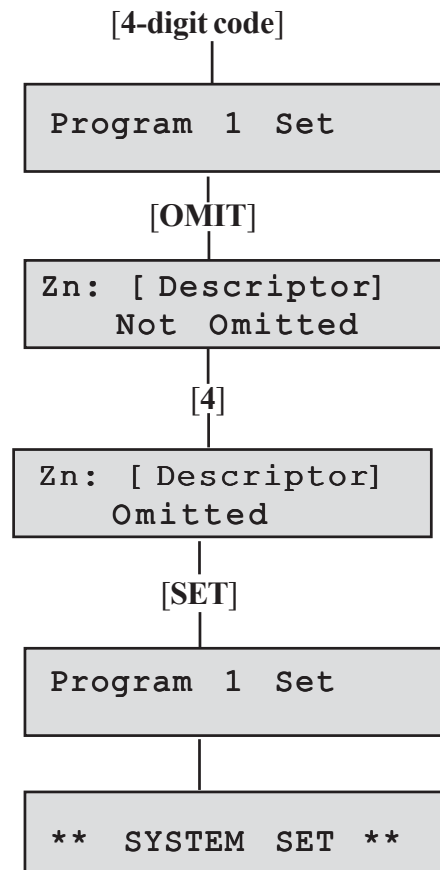

LED Keypad:

- Enter your [4-digit code] to start the exit procedure (for more information see **How to Set the System**).
- Press [OMIT] and the exit beep tone will stop, and all LED's for used zones that can be omitted will come on.
- Press the zone [number] to be omitted. The LED will now flash to show the zone as omitted. If a flat reject tone is heard, then the zone cannot be omitted.
- Press [SET] or allow the system to set.

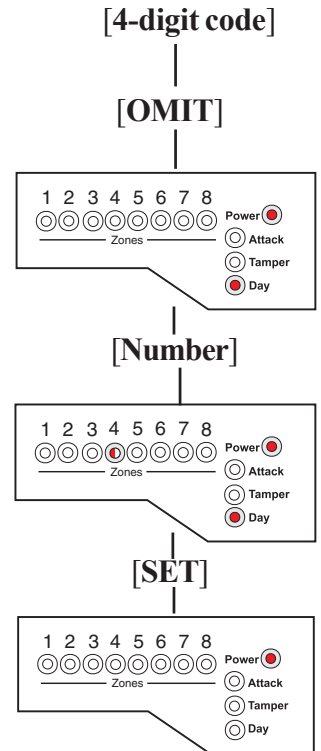

How to Quick Set the System

When you set the system you will usually have about 30 seconds to exit the premises. This also means that you need to wait 30 seconds for the system to set. You can reduce this time to just five seconds by carrying out a **Quick Set**.

- Enter your [4-digit code] to start the exit procedure. The exit beep tone will start. (For more information see **How to Set the System**).
- Press [SET] to Quick Set the system and the exit beep tone will change to a more rapid tone. The system will set in five seconds, and the exit tone will stop.

Single Key Setting

If enabled by the engineer, the setting process can be started by pressing Set, rather than entering a user code.

How to Set Up Chime Mode

Chime is a low security facility for use when the system is unset. It is particularly useful in a shop to warn of customers presence, or in a house to warn when a back door has been opened. When a Chime zone detects movement the system will produce a brief two-tone sound, and the Zone LED will come on.

To set any zone to Chime.

LCD Keypad:

- The system should be in **Day** mode (System Unset).
- Press **[CHIME]**. The screen will show the first zone that is already set up for Chime (possibly none).
- Press the zone **[number]** to toggle it in and out of chime.
- When you have finished using the Chime mode press **[RESET]** or wait a few seconds for the display screen to show **Day** mode.

NOTE: **Zn** = Zone number

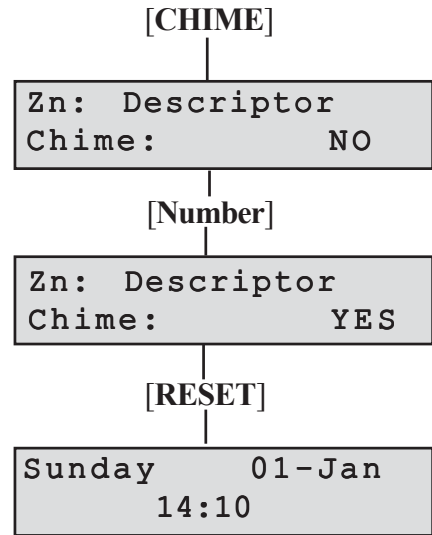

LED Keypad:

- The system should be in **Day** mode (System Unset).
- Press **[CHIME]**. The zone LED's will come on to show those zones that are already set up for Chime (possibly none).
- Press the zone **[number]** to toggle it in and out of chime.
- When you have finished using the Chime mode press **[RESET]** or wait a few seconds. The zone LED goes off.

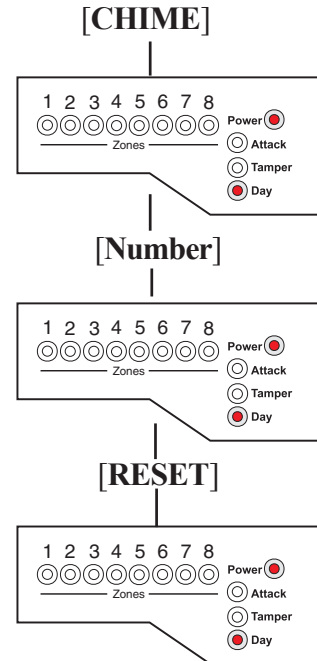

Changing Codes Using User 1

You should change your code regularly to prevent potential intruders from knowing your code. All codes are 4-digits. The factory set code is [0][1][2][3]. User code 1 can only be changed by user 1.

To change user code:

LCD Keypad:

- Press [PROG] and then enter your code [0][1][2][3]. The Day LED goes off to indicate that you are in Programming mode. The first menu **Walk Test** appears on the screen.
- Press the [8] button on the keypad to enter User Set-Up.
- Press the [1] or [2] button on the keypad to edit the required user.
- Enter the new [4-digit code]. If the code is accepted the system will produce a double beep. If it is rejected the code may already be in use and the system will produce a flat tone. You must choose a different 4-digit code.
- Upon the last keypress the code is saved.
- Press [RESET] twice to exit Programming mode. The Day LED will come on with the screen in Day mode.

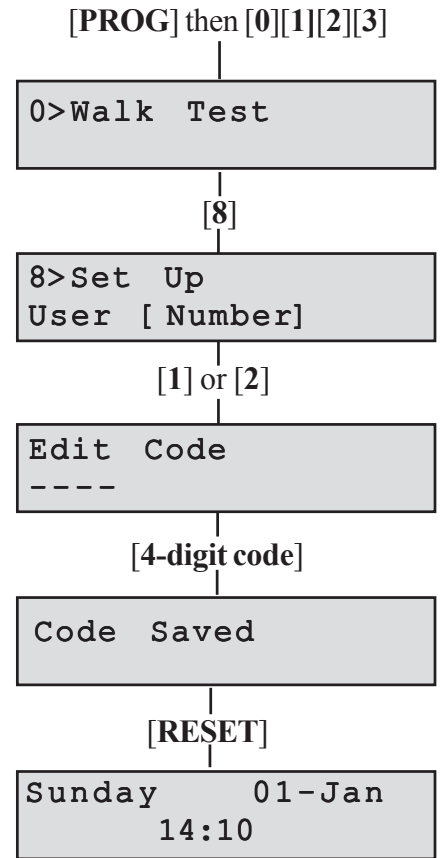

LED Keypad:

- Press [PROG] and then enter your code [0][1][2][3]. The **Tamper (TA)** LED comes on and the **Day** LED goes off to indicate that you are in Programming mode.
- Press the [8] button on the keypad. LED's 1 and 2 are on to indicate that you have two options, user 1 and user 2.
- Press the [1] or [2] button on the keypad to edit the required user. LED's 1-4 are on.
- Enter the new [4-digit code]. If the code is accepted the system will produce a double beep. If it is rejected the code may already be in use and the system will produce a flat tone. You must choose a different 4-digit code.
- Upon the last keypress the code is saved. LED's 1-4 are off.
- Press [RESET] twice to exit Programming mode. The **Day** LED comes on and the **Tamper (TA)** goes off.

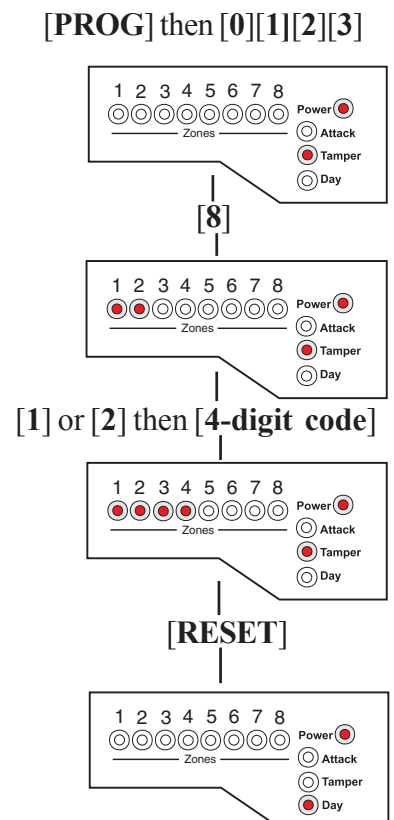

Changing Codes Using User 2

Your alarm system can have a second user code. You may find it useful to set up user code 2 for use by a neighbour for use when you are on holiday. User code 2 operates like user code 1, but it cannot be used to change or delete user code 1.

To change user code 2:

LCD Keypad:

- Press **[PROG]** and then enter user 2 **[four-digit code]**. The Day LED goes off to indicate that you are in Programming mode. The first menu **Walk Test** appears on the screen.
- Press **[8]** to edit user 2.
- Enter the new **[4-digit code]**. If the code is accepted the system will produce a double beep. If it is rejected the code may already be in use and the system will produce a flat tone. You must choose a different 4-digit code.
- Upon the last keypress the code is saved.
- Press **[RESET]** twice to exit Programming mode. The **Day** LED will come on with the screen in **Day** mode.

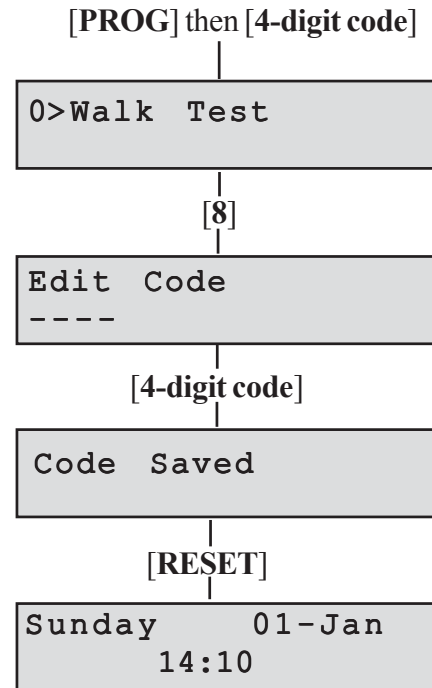

LED Keypad:

- Press **[PROG]** and then enter user 2 **[four-digit code]**. The **Tamper (TA)** LED comes on and the **Day** LED goes off to indicate that you are in Programming mode.
- Press the **[8]** to edit user 2. LED's 1-4 are on.
- Enter the new **[4-digit code]**. If the code is accepted the system will produce a double beep. If it is rejected the code may already be in use and the system will produce a flat tone. You must choose a different 4-digit code.
- Upon the last keypress the code is saved. LED's 1-4 are off.
- Press **[RESET]** twice to exit Programming mode. The **Day** LED comes on and the **Tamper (TA)** goes off.

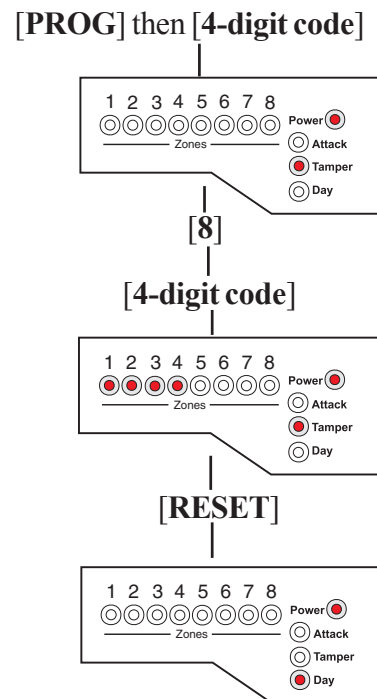

How to Delete User Code 2

You can delete the second code to prevent it being used. User 1 or user 2 can delete user code 2.

To delete user code 2 using user code 1

LCD Keypad:

- Press [PROG] and then enter your code [0][1][2][3]. The Day LED goes off to indicate that you are in Programming mode. The first menu **Walk Test** appears on the screen.
- Press the [8] button on the keypad to enter User Set-Up.
- Press [2] to edit user code 2.
- Press [OMIT] to delete user code 2.
- The message **Code Deleted** is displayed on the screen.
- Press [RESET] twice to exit Programming mode. The Day LED will come on with the screen in **Day** mode.

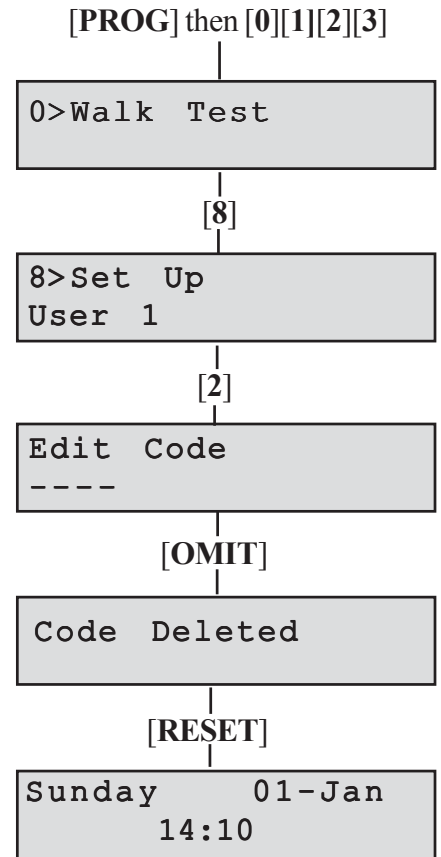

LED Keypad:

- Press [PROG] and then enter your code [0][1][2][3]. The Day LED goes off to indicate that you are in Programming mode.
- Press the [8] button on the keypad to enter User Set-Up. LED's 1 and 2 are on.
- Press [2] to edit user code 2. LED's 1-4 are on.
- Press [OMIT] to delete user code 2.
- User code 2 is deleted. LED's 1-4 are off.
- Press [RESET] twice to exit Programming mode. The Day LED comes on and the Tamper (TA) goes off.

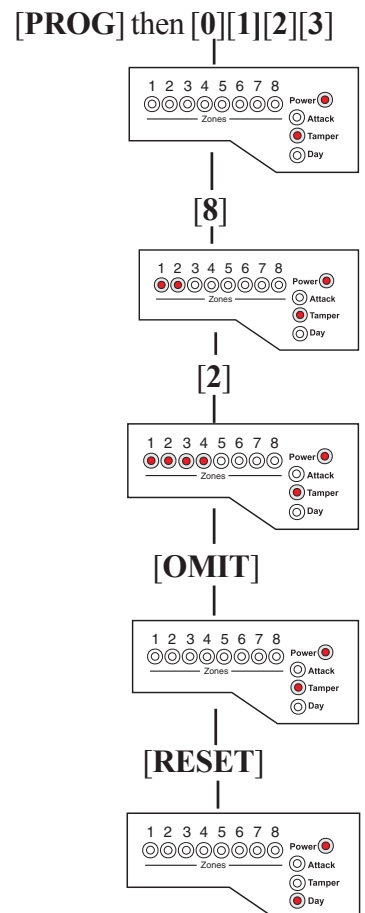

To delete user code 2 using user code 2

LCD Keypad:

- Press **[PROG]** and then enter the user 2 **[4-digit code]**. The **Day** LED goes off to indicate that you are in Programming mode. The first menu **Walk Test** appears on the screen.
- Press the **[8]** button on the keypad to edit user code 2.
- Press **[OMIT]** to delete user code 2.
- The message **Code Deleted** is displayed on the screen.
- Press **[RESET]** twice to exit Programming mode. The **Day** LED will come on with the screen in **Day** mode.

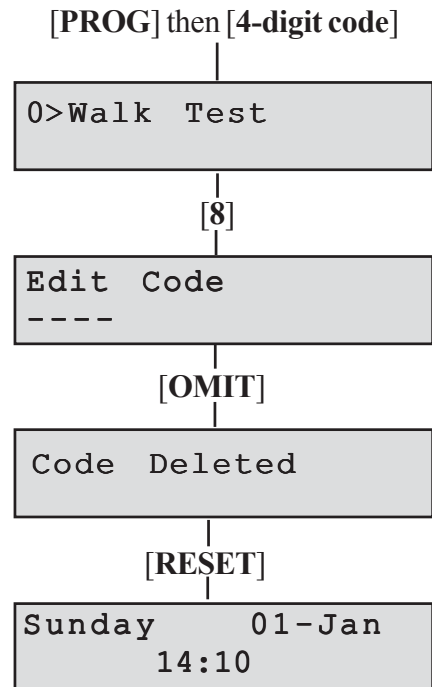

LED Keypad:

- Press **[PROG]** and then enter the user 2 **[4-digit code]**. The **Day** LED goes off to indicate that you are in Programming mode.
- Press the **[8]** button on the keypad to edit user code 2. LED's 1-4 are on.
- Press **[OMIT]** to delete user code 2.
- User code 2 is deleted. LED's 1-4 are off.
- Press **[RESET]** twice to exit Programming mode. The **Day** LED comes on and the **Tamper (TA)** goes off.

[PROG] then [4-digit code]

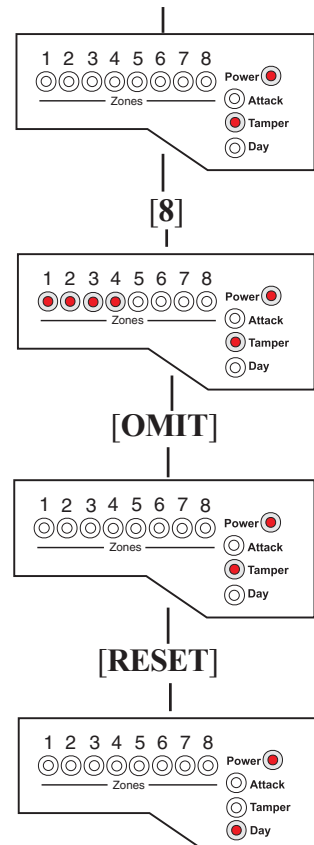

Duress Code

Your alarm system can have a duress code. The Duress code is used in a hold-up situation where there is pressure to set or unset the system. The Duress code operates like your normal code but in addition it will silently send a signal to the Alarm Receiving Centre. The operator at the ARC may request the Police to attend your premises.

The duress code can only set up, edited and deleted by the installer while in *Engineer program mode*.

NOTE: The Duress code facility is not applicable to the **Optima compact** system.

How to View the Event Log

1 = LCD Keypad:

The event log gives a display of all the events that have taken place. The events are arranged by date and time. Up to 250 events can be stored in the memory. When the log reaches 250 events and another event takes place, the oldest event drops out.

To view the event log:

- Press [**PROG**] and then enter your code [0][1][2][3]. The **Day** LED goes off to indicate that you are in Programming mode. The first menu **Walk Test** appears on the screen.
 - Press [**CHIME**].
 - Choose [1] for Event Log in LCD screen.
 - The last event (250) appears on LCD screen.
- To go forward through the event log in sequence, press [**OMIT**].
To go back through the event log in sequence, press the [**up arrow**].

- Press [**RESET**] twice to leave the menu.

To go to a specific event:

- Press the [**PROG**] button.
- Key in Event Number you want to see (eg 150).
- Press the [**SET**] button. The event appears on the LCD screen.
- Press [**SET**] again to see further details of the event.
- Press [**RESET**] twice to leave the menu option.

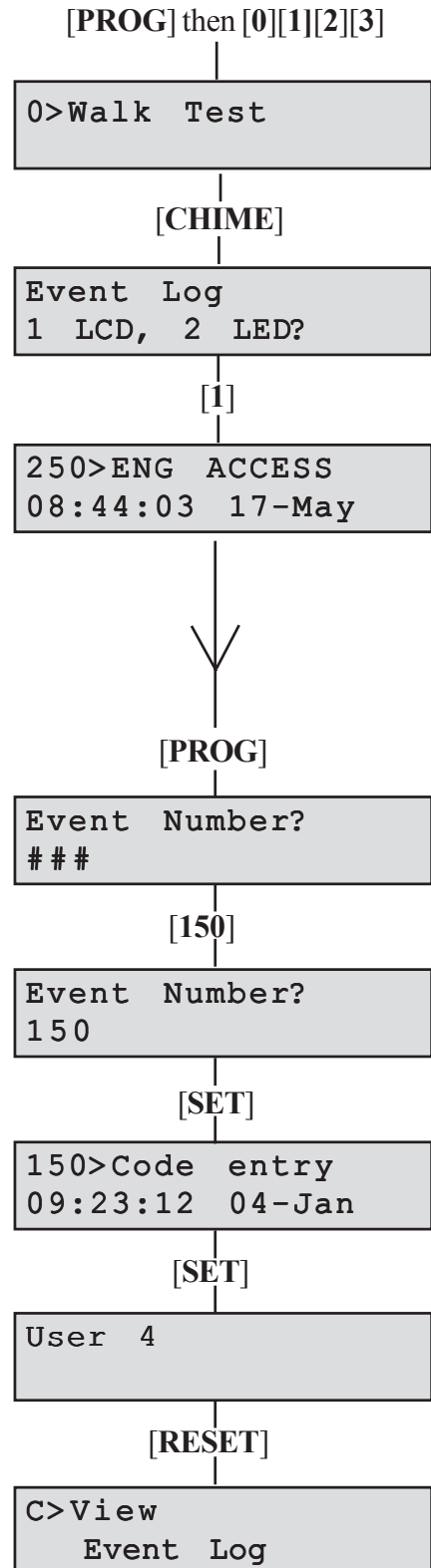

2 = LED Keypad:

The LED keypad is limited to show the last eight set periods with the eighth being the oldest. **Zone**, **Attack (PA)** and **Tamper (TA)** LED's will be on to show zone in alarm. Flashing LED indicates the first zone in alarm. **Day** indicates the status of the panel at the time of the alarm.

- Press [**PROG**] and then enter your code [**0**][**1**][**2**][**3**]. The **Day** LED goes off and the **Tamper (TA)** LED comes on to indicate that you are in Programming mode.
- Press [**CHIME**] to enter into Event Log menu. LED's 1 and 2 are on.
- Press [**2**] for LED keypad. The first zone to activate is indicated by a flashing LED.
- Press [**1 to 8**] for the desired event or [**CHIME**] to go through events in sequence.
- Press [**RESET**] twice to leave the menu.

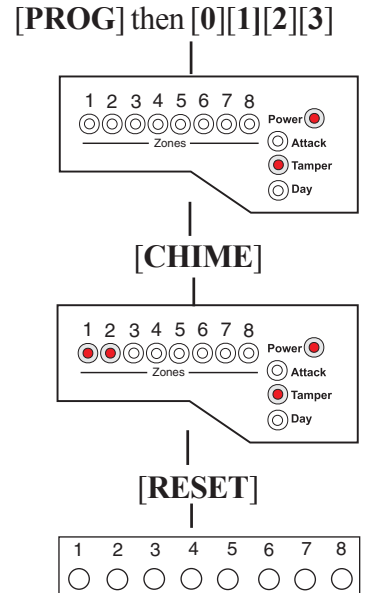

How to Test Your Alarm system

You should check that your alarm system still works correctly by periodically carrying out the alarm system tests described here.

How to Test the Bell, Strobe and Internal Sounder

This function tests the alarm function of the Bell, Strobe or Internal Sounder. Pressing the appropriate button [**1-3**] toggles the function ON or OFF. Using the [**up arrow**] also selects the appropriate alarm function.

Pressing the [**0**] button turns all alarm outputs to OFF.

Pressing the [**SET**] button toggles the selected alarm output.

Pressing the [**RESET**] button turns off all outputs and leaves the function.

The outputs are:

1 = Bell, 2 = Strobe, 3 = Sounder

NOTE: To test the Low volume sounder enable option 3 only. To test for a high volume sounder enable both options 2 and 3 together.

LCD Keypad:

- Press **[PROG]** and then enter your code **[0][1][2][3]**. The **Day** LED goes off to indicate that you are in Programming mode. The first menu **Walk Test** appears on the screen.
- Press **[up arrow]** for menu **Alarm Test**.
- Press **[1]** or **[SET]** to enter into first function ON or OFF.
- Press the **[up arrow]** or number **[2]** or **[3]** for the other functions.
- Press **[RESET]** to leave the menu.

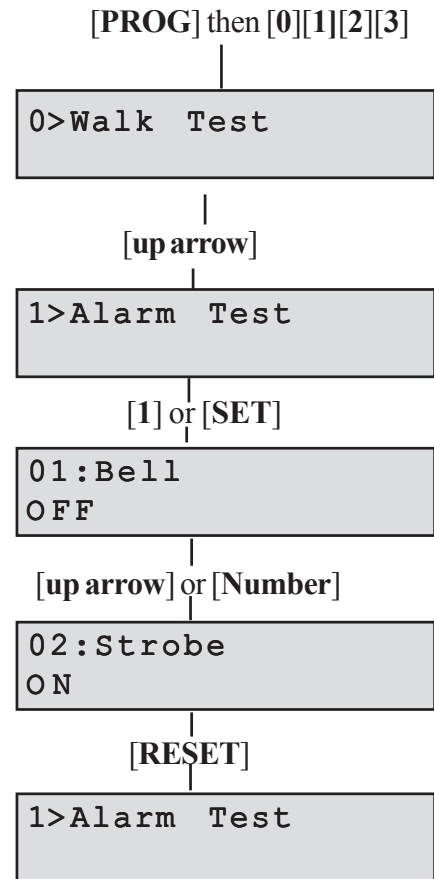

LED keypad

- Press **[PROG]** and then enter your code **[0][1][2][3]**. The **Day** LED goes off and the **Tamper (TA)** LED comes on to indicate that you are in Programming mode.
- Press **[1]** for menu **Alarm Test**.
- Press **[1]** or **[SET]** to toggle first function ON or OFF.
- Press number **[2]** and **[3]** for the other functions.
- Press **[RESET]** twice to exit Programming mode. The **Day** LED comes on and the **Tamper (TA)** LED goes off.

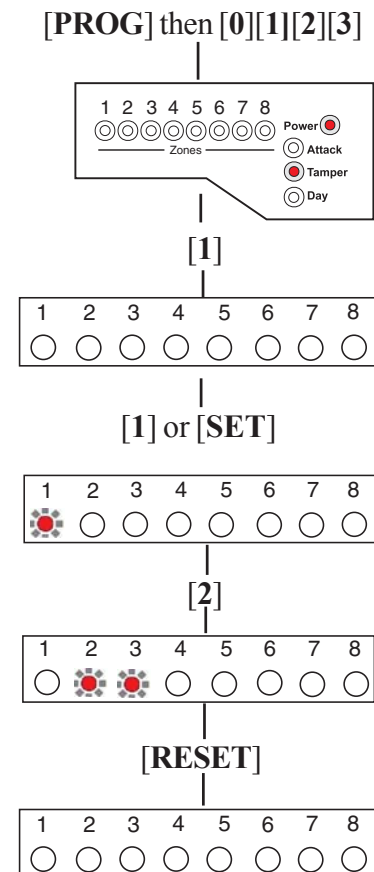

How to do a Walk Test

Walk around your property, and in turn cause each detector to go into alarm. Also, open and close all door and windows that are protected by the system. For each detector (including door or window sensor) that is activated the system will produce a series of beeps, and the associated zone will be indicated on the keypad.

NOTE: Do not test any **Personal Attack, Fire or Tamper** buttons during the Walk Test since these are still active and will cause a full alarm.

If any of the tests fail, or you are unsure of the correct procedure, contact your installer

LCD Keypad:

- Press [**PROG**] and then enter your code [**0**][**1**][**2**][**3**]. The **Day** LED goes off to indicate that you are in Programming mode. The first menu **Walk Test** appears on the screen.
- Press [**SET**] or [**0**]. Zones 1-8 have a zero (0) below each number.
- When a zone is successfully tested, number 1 replaces the 0. Zones are added to list as each one is activated.
- Press [**RESET**] to leave the menu or [**SET**] to restart the Walk Test.

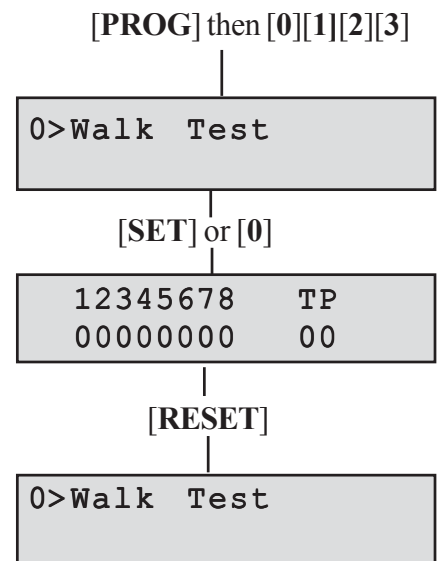

LED keypad

- Press [**PROG**] and then enter your code [**0**][**1**][**2**][**3**]. The **Day** LED goes off and the **Tamper (TA)** LED comes on to indicate that you are in Programming mode, **Walk Test**
- Press [**SET**] or [**0**]. Zones 1-8 are off.
- When a zone is successfully tested, the LED is on. Zones are added to list as each one is activated.
- Press [**RESET**] to leave the menu or [**SET**] to restart the Walk Test.

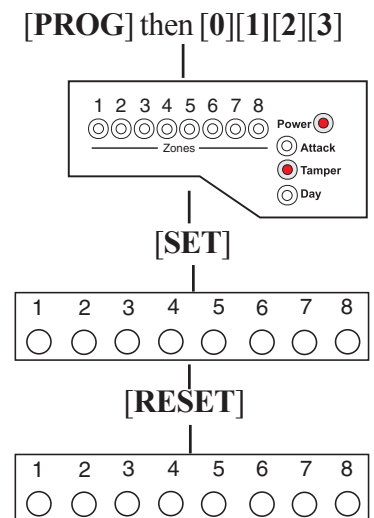

How to Set up the Time and Date

LCD Keypad:

- Press **[PROG]** and then enter your code **[0][1][2][3]**. The **Day** LED goes off to indicate that you are in Programming mode. The first menu **Walk Test** appears on the screen.
- Press **[4]** and the **Time and Date** Screen appears.
- The **Time** can be modified in hours, minutes and seconds in the format HH:MM:SS. The number keys on the keypad 0-9 are used for this function. As each digit is modified the cursor moves to the next one. When the time is correct press the **[SET]** button to accept the change and move to the next screen or
- To cancel the change press the **[RESET]** button twice.
- The **Date** can be changed in day , month, year format DD-MM-YY. The number keys on the keypad 0-9 are used for this function. As each digit is modified the cursor moves to the next one. When the date is correct press the **[SET]** button to accept the change or
- To cancel the change press the **[RESET]** button twice.

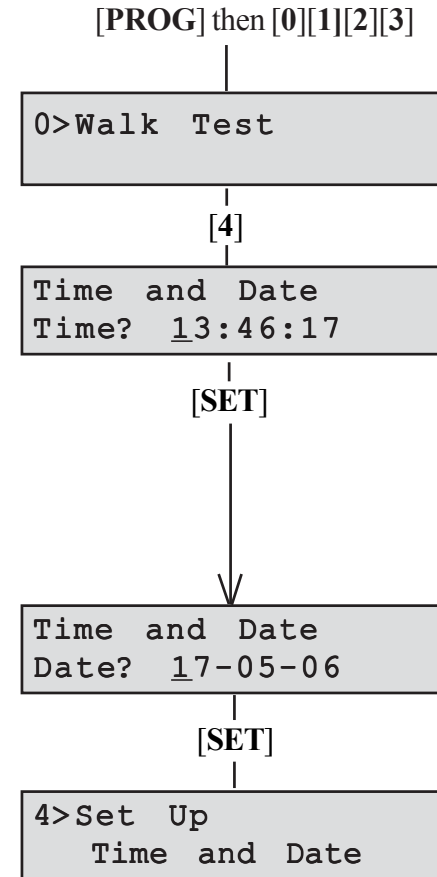

LED Keypad:

If required, the time and date can be entered as per the procedure for the LCD keypad. However no information will be indicated on the LED keypad. The only indication on the LED keypad that you are in menu 4 **Set up Time and Date** is that LED's 1 to 6 on the LED Keypad will be ON.

External Siren Time: _____

Siren delay: _____

Area Protected		Zone Name	Program 1	Program 2	Program 3
Zone 1					
Zone 2					
Zone 3					
Zone 4					
Zone 5					
Zone 6					
Zone 7					
Zone 8					

T = Timed (Entry/Exit Zone)

TI = Timed Inhibited (Access zone to keypad)

I = Immediate



The panels conform to the requirements of the European EMC and Low Voltage directives, and carries the CE mark

Activ8 PIR

8IR103

PIR MOTION DETECTOR

With PET IMMUNITY up to 25Kg

INSTALLATION INSTRUCTIONS

English

P/N 7101507 REV. B A.Y.

PRODUCT DESCRIPTION

The Activ8 PIR detector uses a special designed optical Lens with unique Quad (Four element) PIR Sensor and new ASIC based electronics optimized to eliminate false alarms, caused by small animals and Pets. The Activ8 PIR provides unprecedented levels of immunity against visible light. The Detector offers an exceptional level of detection capability and stability for every security installation. The Activ8 PIR is supplied with Wide Angle lens.

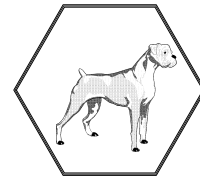

The Activ8 PIR provides Pet immunity up to 25Kg (55 lbs). For better immunity avoid installation in areas where pets can reach upwards.

Activ8 PIR FEATURES

FEATURES

- Quad Linear Imaging Technology for sharp analysis of body dimensions and differentiation from background and animals.
- New ASIC based electronics.
- Immunity to animals up to 25kg (55 lbs).
- 18m Detection Range with Wide Angle Lens.
- Temperature compensation.
- Compact Design for Residential Installation.
- Variable pulse width adjustment.
- Sensitivity adjustment.
- Environmental immunity.
- Height installation calibration free (1.8m – 2.4m).
- LED Remote function.

DETECTION PATTERN

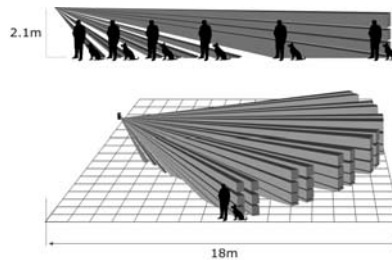

TYPICAL INSTALLATION

SELECT MOUNTING LOCATION

Choose a location most likely to intercept an intruder. See detection pattern. The Quad high quality sensor detects motion crossing the beam; it is less sensitive detecting motion towards the detector. The Activ8 PIR performs best when provided with a constant and stable environment.

AVOID THE FOLLOWING LOCATIONS

- * Facing direct sunlight.
- * Facing areas subject to rapid temperature changes.
- * Areas with air ducts or substantial air flows.

REMOVAL OF FRONT COVER

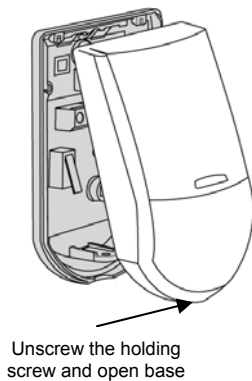

Unscrew the holding screw and open base

MOUNTING THE DETECTOR

1. To remove the front cover, unscrew the holding screw and gently raise the front cover.
2. To remove the PC board, carefully unscrew the holding screw located on the PC board.
3. Break out the desired holes for proper installation.
4. The circular and rectangular indentations at the bottom base are the knockout holes for wire entry. You may also use mounting holes that are not in use for running the wiring into the detector. (For option with bracket - lead wire through the bracket)
5. Mount the detector base to the wall, corner or ceiling. (For option with bracket install bracket).
6. Reinstall the PC board by fully tightening the holding screw. Connect wire to terminal block.
7. Replace the cover by inserting it back in the appropriate closing pins and screw in the holding screw.

KNOCKOUT HOLES

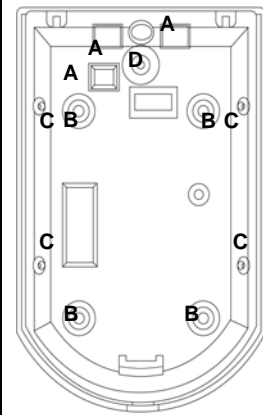

- A. Wire access holes
- B. Use for flat wall mounting
- C. Corner mounting - use all 4 holes. Sharp left or right angle mounting - use 2 holes (top and bottom)
- D. For bracket mounting

DETECTOR INSTALLATION

TERMINAL BLOCK CONNECTIONS

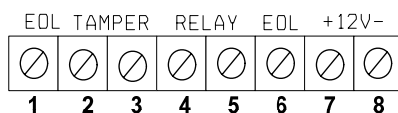

Terminals 1 & 6 - Marked "EOL" - End of line option.

Terminals 2 & 3 - Marked "TAMPER"

If a Tamper function is required connect these terminals to a 24-hour normally closed protective zone in the control unit. If the front cover of the detector is opened, an immediate alarm signal will be sent to the control unit.

Terminals 4 & 5 - Marked "RELAY"

These are the output relay contacts of the detector. Connect to a normally closed zone in the control panel.

Terminal 7 - Marked "+" (+12V)

Connect to a positive Voltage output of 8.2 - 16Vdc source (usually from the alarm control unit)

Terminal 8 - Marked "-" (GND)

Connect to the negative Voltage output or ground of the control panel.

PCB LAYOUT

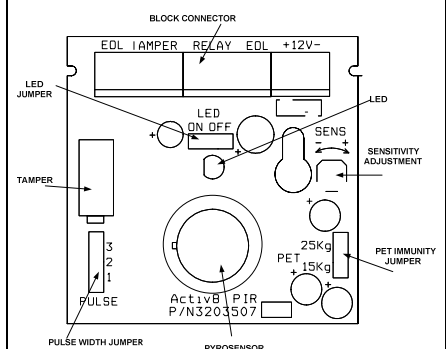

SETTING-UP THE DETECTOR

PULSE WIDTH JUMPER SETTING

 3 Very stable environment
 2 Jumper #1 = ON
 1 Without PET

PULSE

 3 Moderate nuisance situation
 2 Jumper #2 = ON
 1 PET up to 15 kg (33.1 lb)

PULSE

 3 Relatively high chance of false alarms
 2 Jumper #3 = ON
 1 PET up to 25 kg (55 lb)

PULSE

LED ENABLE JUMPER SETTING

LED ON OFF

LED ON

LED ON OFF

LED OFF

PET IMMUNITY JUMPER SETTING

25Kg
 15Kg

Immunity to an animal up to 15 kg

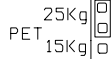
25Kg
 15Kg

Immunity to an animal up to 25 kg

PIR SENSITIVITY ADJUSTMENT

POTENTIOMETER— adjustment according to protected area range.
 Use the potentiometer to adjust the detection range between 68% and 100% (factory set to 84%). Rotate the potentiometer clockwise to increase range, counter-clockwise to decrease range.

WIRE SIZE REQUIREMENTS

Use #22 AWG (0.5 mm) or wires with a larger diameter. Use the following table to determine required wire gauge (diameter) and length of wire between the detector and the control panel.

Wire Length	m	200	300	400	800
Wire Diameter	mm	.5	.75	1.0	1.5
Wire Length	ft.	800	1200	2000	3400
Wire Gauge	#	22	20	18	16

TESTING

TEST PROCEDURES

WAIT FOR ONE MINUTE OF WARM UP TIME AFTER APPLYING 12 VDC POWER. CONDUCT TESTING WITH THE PROTECTED AREA CLEARED OF ALL PEOPLE.

Walk test

- Remove front cover.
The pulse jumper must be in position 1. The LED must be enabled.
- Replace the front cover.
- Start walking slowly across the detection zone.
- Observe that the detector's LED lights whenever motion is detected.
- Allow 5 sec. between each test for the detector to stabilize.
- After the walk test is completed, the LED may be disabled.

NOTE:

Walk tests should be conducted, at least once a year, to confirm proper operation and coverage of the detector.

BRACKET INSTALLATION OPTION

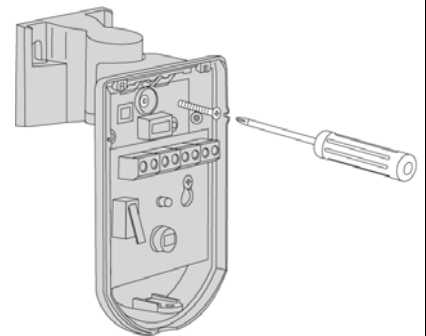
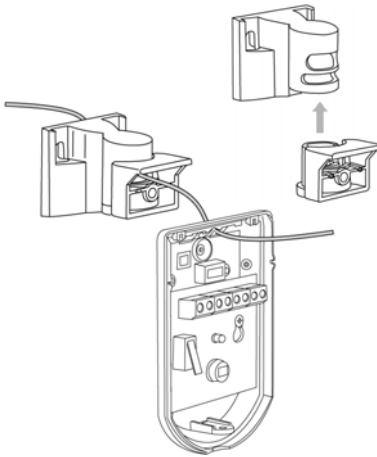

WALL AND CEILING INSTALLATION OPTIONS

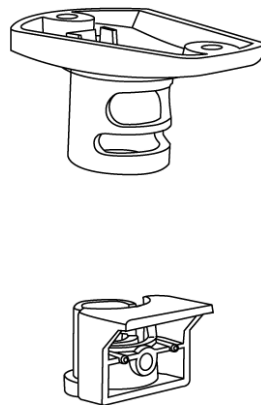
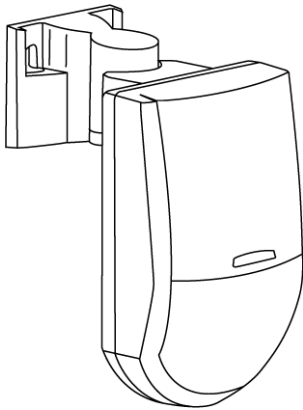

REPLACING THE LENS

- Remove the front cover.
- Using a small flat screwdriver, press on left and right snaps of the lens and pull the lens out from its place (front cover side).
- Replace a new lens.
- Push the lens to its place by pressing again from outside of the front cover until a click is heard.
- Replace front cover.

TECHNICAL SPECIFICATION

MODEL	Activ8 PIR
Detection Method	Quad (Four element) PIR
Power Input	7.8 to 16 VDC
Current Draw	Standby: 8mA (± 5%) Active: 10mA (± 5%)
Temperature Compensation	YES
Pulse Width	Adjustable
Alarm Period	2 sec (± 0.5sec)
Alarm Output	N.C 28VDC 0.1 A with 270hm series protection resistor
Tamper Switch	N.C 28VDC 0.1A with 10 Ohm series protection resistor - open when cover removed
Warm Up Period	60sec (± 5sec)
LED Indicator	LED is ON during alarm
Operating Temperature	-20°C to +60°C (-4°F to +140°F)
RFI Protection	30V/m 10 - 1000MHz
EMI Protection	50,000V of electrical interference from lightning or power through
Dimensions	90mm x 59mm x 37mm (3.54" x 2.32" x 1.46")
Weight	40gr (1.4oz)

Honeywell Security & Communications
 (UK64)Newhouse Industrial Estate
 Motherwell
 Lanarkshire
 ML1 5SB
 Tel +44 (0)1698 738200
 Fax +44 (0)1698 738300
 Tech Support: +44 (0)844 8000 235
www.honeywell.com/security/uk/intruder

Honeywell

Activ8 PIR

8IR103

DETECTOR DE MOVIMIENTO PIR CON INMUNIDAD A MASCOTAS

INSTRUCCIONES DE INSTALACION

Spanish

DESCRIPCION DEL DETECTOR

El detector Activ8PIR usa una lente especialmente diseñada con cuádruple elemento de detección y electrónica basada en tecnología ASIC para eliminar las falsas alarmas causadas por pequeños animales y mascotas.

El detector Activ8 PIR proporciona altos niveles de inmunidad frente a la luz visible.

El detector ofrece un óptimo nivel de detección y estabilidad para cada instalación de seguridad.

El detector Activ8 PIR se suministra con óptica de gran angular.

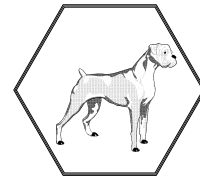

El detector Activ8 AM incluye inmunidad contra mascotas de hasta 25Kg. Para mayor seguridad, se debe evitar su instalación en lugares en los que puedan acercarse las mascotas.

CARACTERÍSTICAS DEL DETECTOR

CARACTERISTICAS

- Cuádruple elemento de detección para análisis de contornos y diferenciación con el fondo y animales.
- Inmunidad contra animales de hasta 25 Kg. activa hasta 1m de distancia del detector.
- Rango de detección de 18m con óptica lente gran angular.
- Compensación de temperatura.
- Diseño compacto para instalaciones residenciales.
- Ajuste de la sensibilidad.
- Ajuste de sensibilidad
- Inmunidad ambiental
- Altura libre de instalación sin ajustes (1.8m – 2.4m).
- Función LED Remoto.

PATRON DE DETECCION

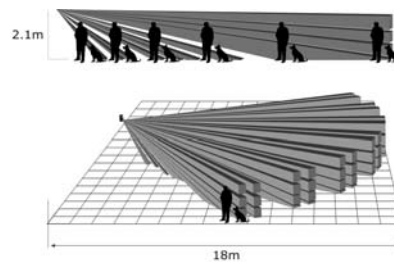

INSALACION TIPICA

INSTALACION DEL DETECTOR

Escoger una localización lo mas apropiada para interceptar una posible intrusión. (La recomendación es la instalación en esquina). Observe las zonas de detección. El elemento de detección detecta movimiento cruzando el haz; la detección es menos sensible cuando el movimiento se realiza hacia el detector.

La detección es mejor si las condiciones ambientales son estables y constantes.

EVITAR LAS SIGUIENTES INSTALACIONES

- De cara directa al sol.
- De cara a zonas con cambios rápidos de temperatura.
- Zonas con corrientes de aire.

El detector Activ8PIR funciona mejor en zonas de ambiente estable.

RETIRADA DE LA CUBIERTA

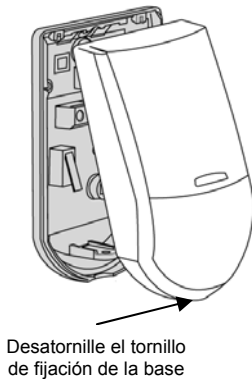

Desatornille el tornillo de fijación de la base

MONTAJE DE LA BASE DEL DETECTOR

8. Para abrir la tapa frontal, afloje el tornillo de cierre, inserte una herramienta fina en el espacio entre la tapa y la base y tire con suavidad, hasta que la tapa se libere.
9. Para retirar la placa, desatornille con cuidado los tornillos situados en la placa.
10. Perfore los orificios adecuados para introducir el cable.
11. Las muescas circular y rectangular situadas en la parte inferior de la base son para la entrada de cables.
12. Monte la base del detector en la pared esquina o techo. (Para opción con soporte, instale éste con la base).
13. Reinstale la tarjeta electrónica con los tornillos. Conecte los terminales.
14. Vuelva a colocar la tapa y apriete el tornillo de fijación.

ORIFICIOS DE FIJACION

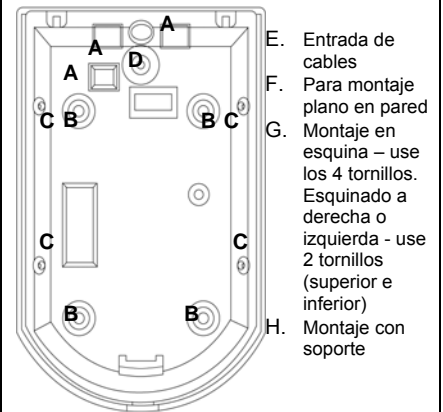

- E. Entrada de cables
- F. Para montaje plano en pared
- G. Montaje en esquina – use los 4 tornillos. Esquinado a derecha o izquierda – use 2 tornillos (superior e inferior)
- H. Montaje con soporte

INSTALACION DEL DETECTOR

TERMINALES DE CONEXION

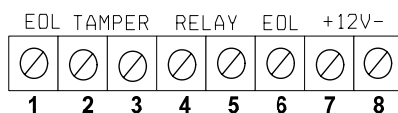

Terminales 1 y 6 - Marcado " EOL " – Opción final de línea.

Terminales 2 y 3 - Marcado " TAMPER "
Si se requiere la función sabotaje, conectar estos terminales a una zona 24 horas normalmente cerrada de la central. En caso de apertura de la tapa del detector, se transmite una alarma de modo inmediato.

Terminales 4 y 5 - Marcado " RELAY "

Contactos del relé de salida del detector. Se deben conectar a una zona normalmente cerrada de la central.

Terminal 7 - Marcado " + " (+12V)

Se debe conectar a una fuente de alimentación 8.2 – 16Vdc (normalmente desde la central).



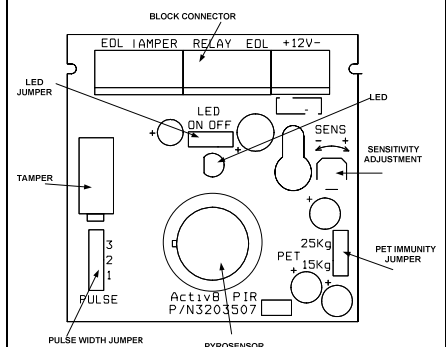

Terminal 8 - Marcado " - " (GND)

Se debe conectar a la salida de negativo de la central.

CIRCUITO ELECTRONICO

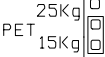
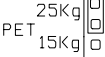

CONFIGURACION DEL DETECTOR

<p>CONFIGURACIÓN SENSIBILIDAD DETECCIÓN</p> <p>  3 Ambiente muy estable 2 Jumper #1 = ON 1 Sin mascota PET </p> <p>PULSE</p> <p>  3 Situación de ruido moderado 2 Jumper #2 = ON 1 Mascotas de hasta 15 kg </p> <p>PULSE</p> <p>  3 Posibilidad relativa de falsas alarmas 2 Jumper #3 = ON 1 Mascotas de hasta 25 kg </p> <p>PULSE</p>	<p>JUMPER HABILITACION DEL LED</p> <p>LED ON OFF  LED ON</p> <p>LED ON OFF  LED OFF</p> <p>CONFIGURACION INMUNIDAD MASCOTAS</p> <p>  25kg PET 15kg Inmunidad de mascotas de hasta 15Kg </p> <p>  25kg PET 15kg Inmunidad de mascotas de hasta 25Kg </p>	<p>AJUSTE SENSIBILIDAD PIR</p> <p>POTENCIOMETRO "PIR" – ajuste según el rango de la zona protegida. Use "PIR" para ajustar el rango de detección entre 68% y 100% (de fábrica en 84%). Gire el potenciómetro en el sentido de las agujas del reloj para aumentar el rango o al revés para disminuir.</p> <p>REQUERIMIENTOS DE CABLEADO</p> <p>Se debe usar #22 AWG (0.5 mm) o cables de diámetro mayor. Use la siguiente tabla para determinar el diámetro necesario y la distancia entre el detector y la central.</p> <table border="1" style="width: 100%; border-collapse: collapse;"> <tr> <td>Longitud cable</td> <td>m</td> <td>200</td> <td>300</td> <td>400</td> <td>800</td> </tr> <tr> <td>Diámetro cable</td> <td>mm</td> <td>.5</td> <td>.75</td> <td>1.0</td> <td>1.5</td> </tr> <tr> <td>Diámetro cable</td> <td>AWG#</td> <td>22</td> <td>20</td> <td>18</td> <td>16</td> </tr> </table>	Longitud cable	m	200	300	400	800	Diámetro cable	mm	.5	.75	1.0	1.5	Diámetro cable	AWG#	22	20	18	16
Longitud cable	m	200	300	400	800															
Diámetro cable	mm	.5	.75	1.0	1.5															
Diámetro cable	AWG#	22	20	18	16															

PROCEDIMIENTO DE TEST INSTALACION DEL SOPORTE

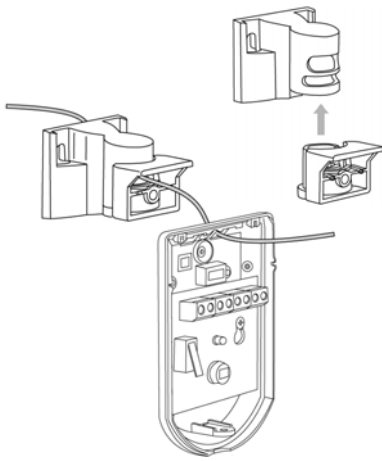
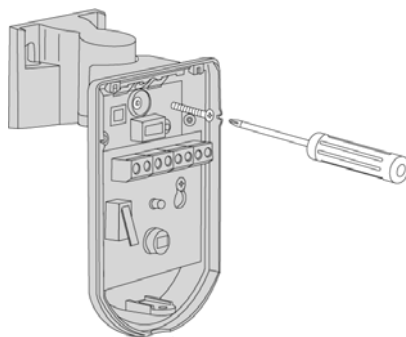
<p>Esperar un minuto para la estabilización de la fuente de alimentación de 12 vcc. Realice un test en áreas donde no haya gente.</p> <p>Test de paseo</p> <ol style="list-style-type: none"> 1. Quitar la tapa Configurar LED en posición ON 2. Montar de nuevo la tapa . 3. Empiece a andar lentamente por la zona de detección. 4. Observe como el LED se activa al detectar movimiento. 5. Permita 5 segundos entre cada prueba para permitir la estabilización del detector. <p>Una vez se ha completado el test, se puede volver el LED a la posición OFF.</p> <p>NOTA: El test de paseo debería realizarse al menos una vez al año, para confirmar el correcto funcionamiento de la cobertura del detector.</p>		
---	--	---

OPCION INSTALACION EN TECHO/PARED SUSTITUCIÓN DE LENTES

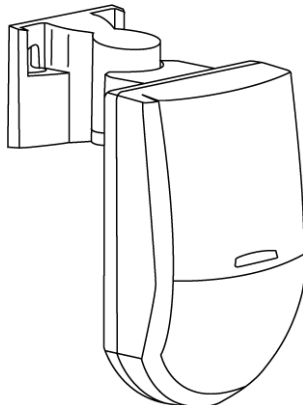
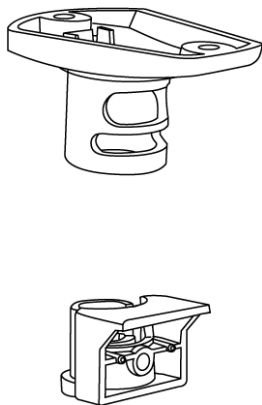
		<ol style="list-style-type: none"> 6. Quitar la tapa 7. Mediante un pequeño destornillador plano, presionar en las pestañas izquierda y derecha de la lente y tire de la lente hasta sacarla de su sitio. 8. Reemplazar la lente. 9. Inserte la lente en su lugar presionando hasta oír un "click". 10. Reemplace la cubierta.
---	---	---

ESPECIFICACIONES TECNICAS

<p>MODELO Activ8 PIR</p> <p>Método de detección Cuádruple elemento PIR</p> <p>Rango de Alimentación 7.8 a 16 Vdc</p> <p>Consumo Reposo: 8mA (±5%) Activo: 10mA (± 5%)</p> <p>Compensación de Temperatura SI</p> <p>Sensibilidad de detección Ajustable</p> <p>Periodo de Alarma 2 segundos (± 0.5seg)</p> <p>Salida Alarma N.C 28Vdc 0.1 A con resistencia de protección de 10 Ohm</p> <p>Contacto Sabotaje N.C 28Vdc 0.1 A con resistencia de protección de 10 Ohm - abierto cuando la tapa está abierta</p> <p>Periodo estabilización 60segundos (± 5seg)</p> <p>LED Indicador LED activado en alarma</p> <p>Temperatura de funcionamiento -20°C to +60°C</p> <p>Protección RFI 30V/m 10 - 1000MHz</p> <p>Protección EMI 50,000V de interferencia eléctrica de luz o alimentación</p> <p>Dimensiones 90mm x 59mm x 37mm</p> <p>Peso 40gr</p>	<p>Honeywell Security & Communications Pol. Ind. Las Mercedes Calle Mijancas, 1, 3º planta 28022 Madrid España Tel: +34 902 667 800 Fax: +34 902 932 503 www.honeywell.com/security/es</p>	
--	--	---

Activ8 PIR

8IR103

IR PASSIVO QUAD
CON IMMUNITA' ANIMALI

ISTRUZIONI DI INSTALLAZIONE

Italian

DESCRIZIONE PRODOTTO

Una nuova generazione di rilevatori di movimento a spettro selettivo, con rilevazione di Infrarossi ad alta definizione.

Activ8 PIR è un rilevatore IR per la protezione antintrusione tramite un sensore Piroelettrico a quadruplo elemento (Quad), che utilizza una lente speciale ad ampio angolo.

L'analisi del segnale IR avviene tramite un microprocessore con tecnologia ASIC, per la compensazione della temperatura, il conteggio degli impulsi dall'elemento PIR, e l'eliminazione di falsi allarmi, come quelli causati da animali di piccola taglia.

Activ8 PIR garantisce un eccezionale livello di affidabilità e stabilità, grazie ad un'elevata immunità alla luce visibile, che lo rende una scelta ottimale per qualsiasi tipo di applicazione di sicurezza.

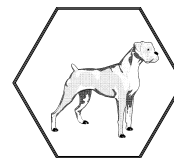

Rilevatore immune alla rilevazione di animali fino a 25Kg circa, per aree con presenza di animali domestici di piccola taglia (inibizione attiva solo al di sotto di 1 m di altezza).

CARATTERISTICHE

- Sensore Piroelettrico a 4 elementi (Quad) con lente rigida per un'eccezionale prestazione di rilevazione ed eliminazione dei falsi allarmi.
- Portata 18x18m
- Design compatto per utilizzo anche in aree domestiche.
- Elettronica basata su processore ASIC di nuova generazione.
- Altezza di installazione senza calibrazione.
- Installazione facilitata con o senza staffe di supporto (opzionali).
- Regolazione della sensibilità PIR.
- Regolazione del conteggio impulsi.
- Compensazione temperatura bidirezionale.
- Immunità ambientale.
- Immunità animali fino a 25Kg h. < 1m.
- LED per funzione remota.

AREA PROTETTA

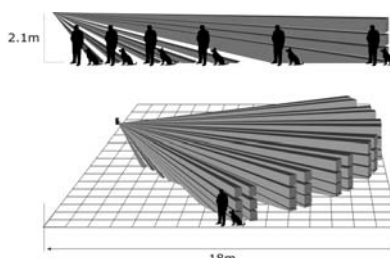

INSTALLAZIONE TIPICA

POSIZIONE DI INSTALLAZIONE

Scegliere la posizione migliore per intercettare un intruso (sono consigliate le installazioni ad angolo), pensando ai possibili percorsi di accesso. Il sensore con elemento quad d'alta qualità rivela il movimento di chi attraversa il fascio in maniera trasversale; la sua sensibilità è leggermente inferiore se il movimento è nella direzione del rivelatore stesso. Altezza di montaggio consigliata tra 1,8 e 2,4m. Activ8 PIR garantisce migliori prestazioni se installato in ambienti con condizioni stabili.

POSIZIONI DA EVITARE

Esposizione diretta alla luce solare.
Aree con rapide variazioni di temperatura
Aree con ventilazione forzata e flussi d'aria molto veloci.

RIMOZIONE DEL COPERCHIO

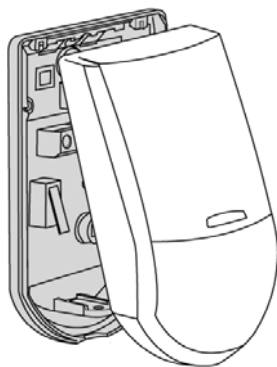

Svitare la vite di tenuta ed aprire la base

MONTAGGIO DELLA BASE

1. Per rimuovere il coperchio, svitare la vite e rimuovere gentilmente la parte frontale.
2. Per rimuovere la scheda elettronica, svitare delicatamente le viti di tenuta sulla scheda.
3. Con un cacciavite, rompere le preforature desiderate.
4. Per l'ingresso dei cavi utilizzare gli appositi fori rettangolari, o i fori di fissaggio inutilizzati (con la staffa di montaggio opzionale, passare i cavi nella staffa stessa).
5. Montare la base del rilevatore sul muro, ad angolo o sul soffitto (con e/o senza staffe di montaggio).
6. Riposizionare la scheda elettronica, fissando delicatamente tutte le viti.
7. Collegare i cavi ai morsetti (vedi sotto).
8. Riposizionare il coperchio inserendolo negli appositi incavi, e serrando la vite di

PREFORATURA DELLA BASE

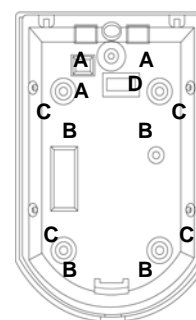

- A. Ingresso cavi
- B. Fori per montaggio su muro piano
- C. Fori per montaggio ad angolo. Usare solo 2 fori (destra o sinistra).
- D. Foro per staffa opzionale di montaggio

INSTALLAZIONE ELETTRICA

MORSETTI DI CONNESSIONE

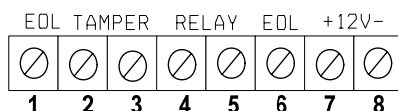

Morsetti 1 & 6 - "EOL" per resistenze di fine linea opzionali (dipendenti dalla centrale antintrusione).

Morsetti 2 & 3 - "TAMPER"

Se è richiesta una protezione tamper 24-ore, collegare questi morsetti al circuito normalmente chiuso di centrale.

Con coperchio chiuso, il circuito tra i due morsetti è normalmente chiuso (N.C.). Aprendo il coperchio, il circuito tra i due morsetti si aprirà immediatamente.

Morsetti 4 & 5 - "RELAY"

Morsetti di allarme. Il circuito tra i due morsetti è normalmente chiuso (N.C.) in caso di funzionamento normale, e si aprirà immediatamente in caso di allarme.

Morsetto 7 - "+ (+12V)"

Alimentazione 12Vdc del rilevatore (8.2 -16Vdc), normalmente fornita dalla centrale antintrusione.

Morsetto 8 - "- (GND)"

Negativo di alimentazione del rilevatore, normalmente fornito dalla centrale antintrusione.

LAYOUT DEL CIRCUITO STAMPATO

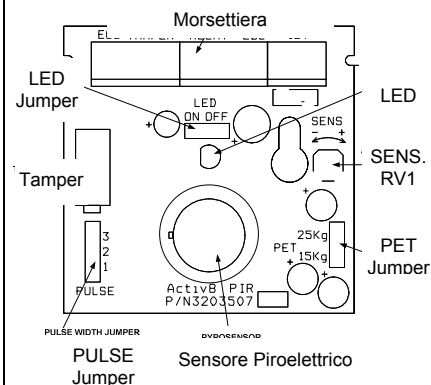

REGOLAZIONI

REGOLAZIONE CONTEGGIO IMPULSI



Ambiente molto stabile e senza animali domestici.
Jumper in posizione 1



Ambiente moderatamente instabile e/o animali domestici fino a 15Kg.
Jumper in posizione 2



Ambiente instabile e/o animali domestici fino a 25Kg.
Jumper in posizione 3

REGOLAZIONE ABILITAZIONE LED



LED abilitato
Jumper in posizione ON



LED disabilitato
Jumper in posizione OFF
La disabilitazione del LED non influisce sul funzionamento dei relè di allarme e tamper

REGOLAZIONE IMMUNITA' ANIMALI



Immunità ad animali fino a 15Kg
Jumper in posizione 15Kg



Immunità ad animali fino a 25Kg
Jumper in posizione 25Kg

REGOLAZIONE PIR SU RV1

Regolazione in conformità della reale area da sorvegliare. Il potenziometro regola il livello di sensibilità dal 68% al 100% (di fabbrica 84%). Ruotare in senso orario per aumentare la sensibilità ed antiorario per diminuirla.

Dopo la regolazione, eseguire un test per la verifica dei corretti parametri di impostazione.

CAVI CONSIGLIATI

Per i collegamenti utilizzare un cavo CEI20-22 con diametro 0.5 mm o superiore. Utilizzare la seguente tabella per determinare il tipo di cavo in relazione alla distanza tra il rilevatore e la centrale antintrusione.

Lunghezza	m	50	200	500	800
Sezione	mm	0.22	0.5	1.0	1.5

PROCEDURE DI TEST

Dopo aver alimentato il rilevatore, attendere durante il tempo di riscaldamento (1 minuto). Eseguire i test in assenza di persone nell'area.

WALK TEST

6. Rimuovere il coperchio. Il PULSE Jumper deve essere in posizione 1, il LED Jumper deve essere abilitato.
7. Riposizionare il coperchio.
8. Camminare lentamente attraverso l'area sorvegliata dal rilevatore.
9. Osservare che il LED si accenda durante il movimento.
10. Attendere 5 sec. Tra i diversi test per lasciare che il rilevatore si stabilizzi.
11. Dopo il test, riposizionare i DIP nella posizione originaria.

Note: il Walk Test andrebbe eseguito almeno una volta all'anno per verificare la reale funzionalità ed efficacia del rilevatore.

MONTAGGIO MECCANICO

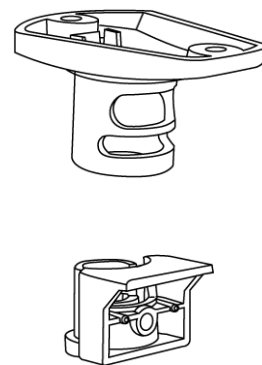
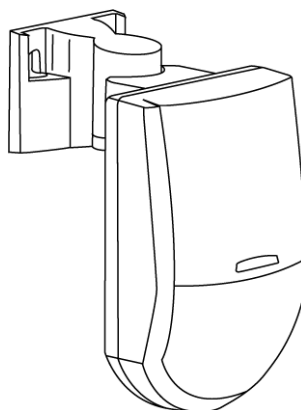

SOSTITUZIONELENTE

1. Rimuovere il coperchio, svitando la vite e rimuovendo gentilmente la parte frontale.
2. Utilizzando un piccolo cacciavite a punta piatta, premere alternativamente sulle linguette laterali della lente, rimuovendola dalla sua sede (sul coperchio frontale).
3. Inserire la nuova lente richiesta.
4. Posizionare la lente nella sede, premendola dalla parte esterna del coperchio, fino a sentire il click che ne confermi l'esatto e completo inserimento.
5. Riposizionare il coperchio inserendolo negli appositi incavi, e serrando la vite di chiusura.

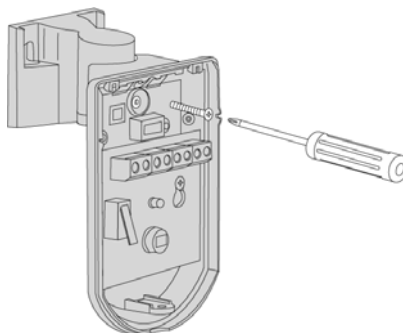

STAFFE OPZIONALI A MURO E A SOFFITTO

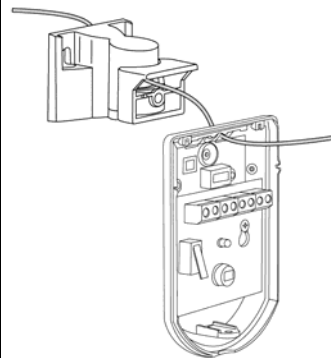

CARATTERISTICHE TECNICHE

Tipo di rilevazione	Quad PIR a 4 elementi
Portata	fino a 18m (con lente normale)
Alimentazione	7.8 a 16 Vdc
Assorbimento	In allarme 10 mA
In stand-by	8 mA
Compensato in temp.	SI
Tempo di allarme	2 +/- 1 sec
Uscite allarme	2 x N.C 28Vdc 0.1A con protezione resistiva da 10 Ohm NB. Tamper aperta con copertura aperta
Tempo di riscaldamento	1 min
LED Indicatore	LED Rosso acceso in allarme
Temperatura di lavoro	da -20°C a +60°C
Dimensioni (HxLxP)	90 x 59 x 37mm
Peso	40 gr.

And for the Italian one please use:
Via della Resistenza 53/59,
20090 Buccinasco
Italia
Tel : +39 0 248 880 51
Fax : +39 0 248 880 55 33
www.honeywell.com/security/it

Honeywell

INSTALLATION INSTRUCTIONS



AG6
EXTERNAL SOUNDER & STROBE

CE

WARNINGS

STROBE CIRCUITS CARRY HIGH VOLTAGES (350 volts.) **ALWAYS** make sure the unit has been disconnected from all external power for **at least 5 minutes** before removing **ANY** safety cover.

WEAR hearing protection when close to a sounder.

ALWAYS observe safety precautions with regard to ladder use.

Plastic bags can suffocate - always dispose of carefully.

NEVER put screwdrivers or other sharp objects in pockets - **ALWAYS** use a tool belt.

STANDARDS

This unit has been tested to the required standards for emission, immunity as set out by the EEC (ECD 89/336/EEC). This unit complies with EN50131-1 which relates to security control equipment.

STANDARD PARTS LIST

1 x AG6 sounder.

1 x Accessory bag containing: - 4 x No 8 Wallplugs, 4 x 2" No 8 screws, Lid screw, screw cap.

This instruction manual Part No F-051-599-00.

INSTALLATION OVERVIEW

Here is a brief description of a typical setup and installation procedure for the AG6.

1. Mount the unit to the desired surface.
2. Connect the AG6 to the control panel.
3. Connect BATT link.
4. Replace covers and tighten the tamper screw.
5. Power up the control panel.

CONNECTIONS

AG 6	R- Negative Tamper Return	V- Negative Supply	ST- Negative Strobe Trigger	V+ Positive Supply	-SW Negative Sounder Trigger
SECURIT 800 Series	R-	V-	ST-	V+	S-
SECURIT 703	R-	0V (NOTE 1)	ST-	BELL+	NO
SECURIT 700L	R-	BELL-	ST-	BELL+	S-
BRAVO 700	R-	BELL-	ST-	BELL+	S-
ACTIVE 5X	21 (NOTE 2)	20 (NOTE 3)	ST-	BELL+	S-
ACTIVE 4	13 (NOTE 2)	12 (NOTE 3)	ST-	BELL+	S-
724 / 764	TAMP RET	V-	INT BELL-	AUX+	EXT BELL-
ARITECH CS350	17	16	7	4	5
VERIFIER 6	TAMP RET	-VE HOLD	- INT BELL	+ EXT BELL	- EXT BELL
ADE	TRO	SCB-	STR	BELL+	BELL-
MENVIER	BELL TAMP	0V	STB	BELL 12V	BELL TRIG
OPTIMA XL4	A	T	STROBE-	D	B
TEXECOM	C	D	S	A	B
SCANTRONIC	TR	0V	STR NO-	12V+	BELL NO-
PARAGON PLUS	BT	B-	STB-	B+	BA
CHALLENGER 5	C	A	ST-	D	B

NOTES FOR TERMINAL CONNECTIONS.

- 1) Link the terminal marked COM to 0V terminal at the panel.
- 2) This should be wired in series with all other tampers and then connected to the pin shown.
- 3) This connection should be the start of the tamper loop and is also used as HOLD OFF negative.

When connecting the bell box to a control panel designed for use in Eire (Ireland) for example the Verifier 6 or Aritech, a diode should be installed as shown below. For panels without a strobe output, Link the ST- to the SW- .

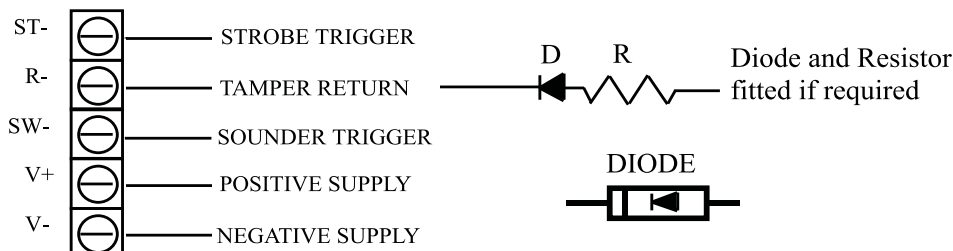

TECHNICAL INFORMATION

HOLD OFF SUPPLY	13.65Vdc nominal 12.0 to 14.5Vdc.
LOAD CURRENT	35mA nom. Quiescent. 260mA nom. Combined sounder and strobe. 125 mA nom. Strobe only.
SOUND OUTPUT LEVEL	110dB @ 1m nom (Supply & Mounting Dependant)
BATTERY	6.0v, 280mAh Nicad. Automatic charging from hold off supply. Design life = 5 years at 20°C nom. Minimum of 3 15 minute alarms from fully charged battery without recharge.
TEMPERATURE RANGE	-20°C to +40°C. Operating & Storage
TRIGGER CONDITIONS	Automatic reset occurs when trigger clears
HOLD OFF	Loss of hold off supply
S-	Negative Trigger (-V applied) Trigger occurs when terminal voltage is less than 3.5v. Maximum load 1.0mA
TAMPER DETECTION TAMPER OUT	Wall & Cover retaining screw Normally closed negative tamper return
CUT OFF TIMER	15 minutes nom. (Sounder Only).
STROBE TRIGGER STROBE	-V applied 0.6 Joules per flash. 1 flash per second nom. @ 13.65Vdc.
DIMENSIONS	H 55mm W 200mm D 300mm
WEIGHT	Gross 840 grams

MOVING THE TAMPER SWITCH

If you are fitting the unit horizontally, you can rotate the AG6 so that the strobe is either to the left or right. However, this would mean in certain cases the tamper screw would be awkward or in the wrong position to tighten. To remove this potential problem, the tamper switch can simply be unclipped from its mounting pins and moved to the opposite side of the base. Make sure the tamper switch is secure before mounting the base.

NOTE:

For correct operation make sure the **BATTERY LINK** is fitted.

The **TAMPER** switch must be closed for the AG6 to get any power from the control panel. This will also power the LED.

NACOSS Regulations.

This unit will conform to NACOSS regulations when installed correctly: In the event that the bell box tamper is opened, this unit will send a tamper signal to the control panel and trigger a local sounder when the system is unarmed .

This product is manufactured to ISO 9001 quality assurance and complies with all relevant standards as set out for EMC. This product is **Year 2000 compliant**.



Certificate No CC106

Please Note:

C&K SYSTEMS are always endeavouring to improve quality and specification of all it's products and may alter or amend this product and instructions without notice. All information is given in good faith but without warranty.

C & K Systems

REDDITCH.

WORCESTERSHIRE

ENGLAND

Tel: +44 (0)1527 68111

Fax: +44 (0)1527 68222

Technical Helpline: 0345 660533 UK Only.

Website: <http://users.powernet.co.uk/cksys>

E-mail: info@cksys.co.uk

