

Wired Passive Infra-Red Movement Detectors

Installation and Operating Instructions

These instructions should be read in conjunction with your System Installation and Operating Manual and be retained for future reference.

Introduction

These Passive Infra-Red (PIR) Movement Detectors are designed for use with Response wired Intruder Alarm systems.

PIR detectors are designed to detect movement in a protected area by detecting changes in infra-red radiation levels caused for example when a person moves within or across the detectors field of vision. If movement is detected, the signal contacts "open" and an alarm signal is generated at the Control Panel (if the system is armed).

Note: Do not exceed the maximum number of PIR detectors permissible for the Zone where the PIR is to be installed or for the system in total. These will be stated in the System Installation and Operating Manual.

Positioning the Detector

The PIR detector is suitable for mounting in dry interior locations only.

It is recommended that the PIR detector is mounted in the corner of a room at a height of approximately 2.2m. At this height the detector will have a 12m range with a 90° field of vision. If required the detector may be mounted at an 8° angle to tilt downwards and change the detection pattern.

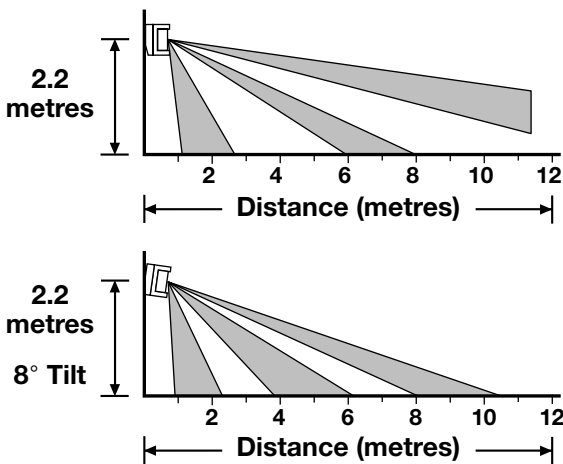

When considering and deciding upon the mounting position for the detector the following points should be considered to ensure trouble free operation:

1. Ideally the detector should be positioned where the logical path of an intruder would cut across the fan detection pattern of the PIR. PIR detectors respond more effectively to movement across the device than to movement directly towards it.
2. Do not position the detector facing a window or where it is exposed to direct sunlight. For this reason PIR detectors are not suitable for use in conservatories.

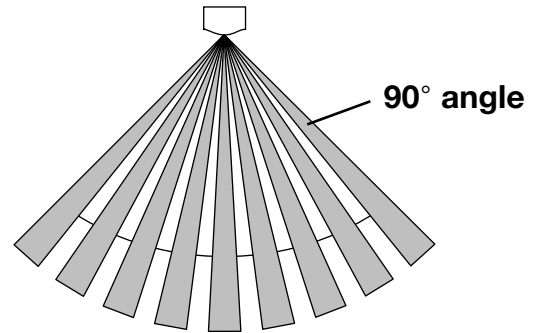

3. Do not position the detector where it is exposed to draughts.
4. Do not position the detector directly above a heat source, (e.g. fire, radiator, boiler, etc).
5. Do not position the detector in a position where it is subject to excessive vibration.

Note: When the system is armed, household pets should not be allowed into an area protected by a PIR as their movement would trigger the PIR and activate the alarm. Alternatively a PIR protected Zone may be 'Omitted' to allow for pet movement. This facility may not be available with all Control Panels, (refer to your System Installation and Operating Manual for details).

Installing the Detector

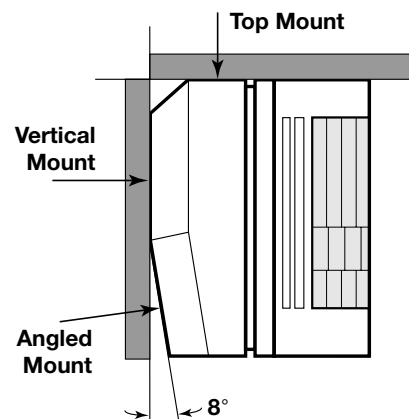

1. Having chosen a suitable position to locate the PIR detector, run the required length of 6 core alarm cable back to the Control Panel.

Do not make any connections at this stage.

2. Slightly loosen the cover retaining screw on the PIR and remove the cover. Carefully remove the PCB by unclipping the PCB retaining clip at the bottom left of the casing.

IMPORTANT: Do not touch the PIR sensor in the middle of the PCB as any marking may impair the unit's performance. If accidentally touched, clean with a dry lint free cloth.

3. The unit can be mounted for the standard 12m range by using the top two side holes, or tilted down by 8° using the bottom

two side holes. Alternatively, the unit can be ceiling mounted using the two holes in the extreme top of the casing.

Cable entry cut outs are provided top and bottom, as required.

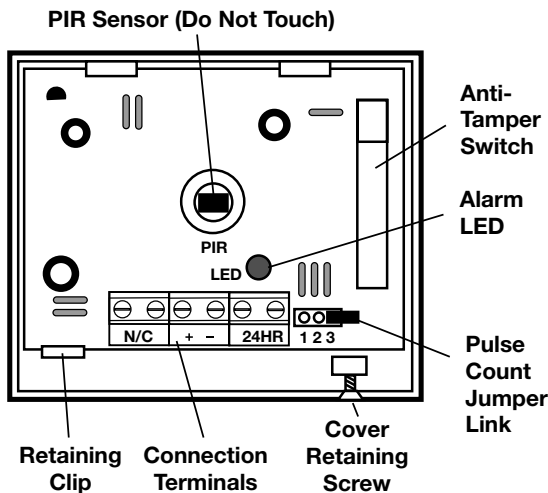

- Carefully cut (or drill) out the required mounting holes and cable entry. Only remove the minimum required number of screw or cable entry holes, to avoid insects entering the detector and causing false triggering.

Mount the unit using two 18mm No.4 screws and 25mm wall plugs as required, (a 5mm hole will be required for the wall plugs).

Note: Do not over-tighten or use larger headed screws when mounting the unit, as this may distort the casing.

Wiring the Detector

IMPORTANT: Before making any connections, ensure that the existing system is fully shut down and all power, (mains and back-up battery) at the Control Panel is removed, (refer to your System Installation and Operating Manual).

It is important that the 12V power supply wiring is connected in parallel with any existing wiring and that the Zone and Tamper circuit wiring is connected in a SERIES loop with existing wiring to the appropriate terminals on the Control Panel.

PLEASE REFER TO YOUR SYSTEM INSTALLATION & OPERATING INSTRUCTION MANUAL FOR FULL CONNECTION DETAILS.

- Thread the cable through the entry on the base, then strip back 5mm of each core, twist the strand ends then fold over and wire into the appropriate terminals on the PIR.

The terminals on the PIR and the wires in the cable are colour coded. The correct colour coding should be followed throughout the entire system.

Note: If your existing system is using a non-standard colour coding system for the wiring, then this must be followed.

Red	+12V supply to PIR, (connect in parallel).
Black	0V supply to PIR, (connect in parallel).
Blue & Yellow	normally closed detector alarm zone circuit, (connect in series).
Green & White	normally closed tamper zone circuit, (connect in series).

Full and detailed wiring instructions are detailed in your System Installation and Operating Manual.

- Carefully refit the PCB into the casing taking care not to touch the PIR detector lens.
- The PIR detector incorporates an anti false alarm feature designed to compensate for situations where the detector may be affected by environmental changes, (e.g. insects, air temperature, etc). This feature is called "Pulse Count" and may be selected for 1, 2 or 3 pulse detection.

The factory default and recommended setting is for 2 Pulse detection. However, in cases of extreme environmental problems, or if unattributable false alarms are experienced, it may be necessary to set "Pulse Count" 3.

Note: The higher the Pulse Count the more movement will be necessary before the PIR detector will trigger the alarm.

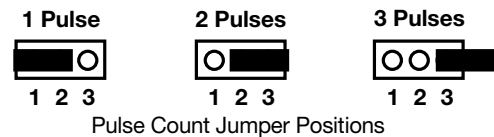

- Refit the cover and tighten the retaining screw.
- The PIR is now ready to be connected to the Control Panel or to an existing PIR detector, and tested.

Testing the Detector

Once the PIR detector has been fully installed, reconnect the power to the alarm system and test the new PIR and the system in accordance with your System Installation & Operating Manual.

Note: After reconnecting the power to the system allow at least 4 minutes for any PIR(s) to stabilise before testing.

Guarantee

Novar ED&S undertakes to replace or repair at its discretion goods (excluding non rechargeable batteries) should they become defective within 1 year solely as a result of faulty materials and workmanship.

Understandably if the product has not been installed, operated or maintained in accordance with the instructions, has not been used appropriately or if any attempt has been made to rectify, dismantle or alter the product in any way the guarantee will be invalidated.

The guarantee states Novar ED&S entire liability. It does not extend to cover consequential loss or damage or installation costs arising from the defective product. This guarantee does not in any way affect the statutory or other rights of a consumer and applies to products installed within the UK and Eire only.

If an item develops a fault, the product must be returned to the point of sale with:

- Proof of purchase.
- A full description of the fault.
- All relevant batteries (disconnected).

Friedland is a trade mark of Novar ED&S.

HELPLINE
If you have a problem with your alarm,
please call the helpline on:

01268 563273
(Lines open 9.00am to 5.00pm, Monday to Friday).



Friedland, Novar Electrical Devices and Systems.
The Arnold Centre, Paycocke Road, Basildon, Essex SS14 3EA.